



PU-507TX-HDVGA

Switchable HDMI & VGA HDBaseT™ Transmitter with Integrated Video Scaling (5Play™ inc. PoC & Single LAN, up to 100m)

OPERATION MANUAL

DISCLAIMERS

The information in this manual has been carefully checked and is believed to be accurate. CYP (UK) Ltd assumes no responsibility for any infringements of patents or other rights of third parties which may result from its use.

CYP (UK) Ltd assumes no responsibility for any inaccuracies that may be contained in this document. CYP (UK) Ltd also makes no commitment to update or to keep current the information contained in this document.

CYP (UK) Ltd reserves the right to make improvements to this document and/or product at any time and without notice.

COPYRIGHT NOTICE

No part of this document may be reproduced, transmitted, transcribed, stored in a retrieval system, or any of its part translated into any language or computer file, in any form or by any means—electronic, mechanical, magnetic, optical, chemical, manual, or otherwise—without express written permission and consent from CYP (UK) Ltd.

© Copyright 2011 by CYP (UK) Ltd.

All Rights Reserved.

Version 1.1 August 2011

TRADEMARK ACKNOWLEDGMENTS

All products or service names mentioned in this document may be trademarks of the companies with which they are associated.

SAFETY PRECAUTIONS

Please read all instructions before attempting to unpack, install or operate this equipment and before connecting the power supply.

Please keep the following in mind as you unpack and install this equipment:

- Always follow basic safety precautions to reduce the risk of fire, electrical shock and injury to persons.
- To prevent fire or shock hazard, do not expose the unit to rain, moisture or install this product near water.
- Never spill liquid of any kind on or into this product.
- Never push an object of any kind into this product through any openings or empty slots in the unit, as you may damage parts inside the unit.
- Do not attach the power supply cabling to building surfaces.
- Use only the supplied power supply unit (PSU). Do not use the PSU if it is damaged.
- Do not allow anything to rest on the power cabling or allow any weight to be placed upon it or any person walk on it.
- To protect the unit from overheating, do not block any vents or openings in the unit housing that provide ventilation and allow for sufficient space for air to circulate around the unit.

REVISION HISTORY

VERSION NO.	DATE	SUMMARY OF CHANGE
v1.03	12/08/14	Added Autoswitching feature, RS-232 and IR pin details
v1.04	25/09/15	Added Bluescreen ON/OFF feature
v1.05	14/01/16	Minor correction to text (4K removed)
v1.06	26/01/16	Minor correction to text (HDCP)
v1.07	07/07/16	Changes to RS-232 commands

CONTENTS

1. Introduction	6
2. Applications	6
3. Package Contents	6
4. System Requirements	6
5. Features	7
6. Operation Controls and Functions	8
6.1 Front Panel	8
6.2 Rear Panel	9
6.3 Remote Control	10
6.4 RS-232 Pin Definitions	11
6.5 IR Cable Pin Assignment	12
6.6 RS-232 Commands	13
Note:	14
6.7 OSD Menu	15
6.8 Input Resolution Support	18
7. Connection Diagram	19
8. Specifications	20
9. Acronyms	21

1. INTRODUCTION

The PU-507TX-HDVGA allows VGA and uncompressed HDMI signals to be transmitted over a Single CAT5e/6/7 cable to lengths of up to 100 metres. This device features full 5-Play convergence allowing the distribution of Video, Audio, LAN serving, Power over Cable (PoC), RS-232 and 2-way IR control functionality over the same CAT5e/6/7 cable. This transmitter allows the user to select and switch between a HDMI or VGA source whilst the integrated scaler ensures maximum resolution support for the connected display.

Additionally, the PU-507TX-HDVGA utilises an auto-scan feature which detects and switches to the last active input.

2. APPLICATIONS

- ///** Scale low resolution video onto High-Definition display
- ///** HDMI/PC signals extension
- ///** Lecture room/Showroom/Meeting room/Classroom display and control

3. PACKAGE CONTENTS

- ///** 1×PU-507TX-HDVGA
- ///** 1× IR Extender
- ///** 1× IR Blaster
- ///** 24V/2.7 A DC Power Adaptor
- ///** Remote control (CR-128)
- ///** Operation Manual

4. SYSTEM REQUIREMENTS

Input HDMI/PC source equipment such as DVD/Video player or PC/Laptop and output to HDBaseT compatible Receiver.

5. FEATURES

- /// Supports all v1.4 HDMI resolutions.
- /// Auto Scan function - scans the inputs for a live signal
- /// Supports uncompressed video/audio up to 10.2Gbps
- /// Common supported resolutions: HDTV: 480p, 576p, 720p, 1080i, 1080p, 1080p24; PC: VGA, SVGA, XGA, WXGA, SXGA, UXGA, WUXGA.
- /// HDMI, HDCP, & DVI compliant
- /// Supports HDCP repeating and CEC functions
- /// Uncompressed data transfer over single CAT cable (100m - CAT6/7; 80m - CAT5e)
- /// Audio support up to 7.1CH & Dolby TrueHD, DTS-HD
- /// 5Play™ convergence: HDMI, LAN, PoC & Control (IR & RS-232)
- /// Supports 3D signals

Note:

1. *This system was tested with CAT6/23AWG cables, results may vary with cables of a different specification.*
2. *The PoC function is designed for powering compatible Receiver units only—non-PoC Receivers will need their own power supply. Receivers of another brand may not be compatible.*

6. OPERATION CONTROLS AND FUNCTIONS

6.1 Front Panel

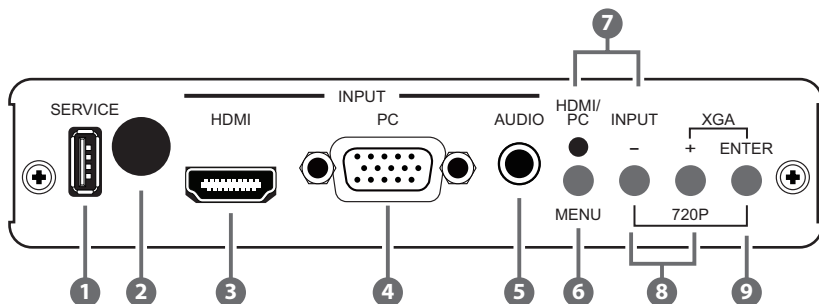

- ① **SERVICE:** This port is reserved for firmware update only.
- ② **IR:** IR Receiver window (accepts the remote control signal of this device only).
- ③ **HDMI:** Connect to source equipment such as DVD/Video player for video signal sending.
- ④ **PC:** Connect with PC/Laptop source equipment for signal input with D-Sub 15 pin cable.
- ⑤ **AUDIO:** Connect to audio source equipment for L/R stereo audio input with 3.5mm phone jack.
- ⑥ **MENU:** Press this button to enter into the OSD menu.
- ⑦ – **INPUT & HDMI/PC LED:** Press to select HDMI or PC source input. When in HDMI mode the LED will illuminate in Red, when in PC mode the LED will illuminated in Green.
- ⑧ **-/+:** Press these buttons to scroll down and up in the OSD selection.
- ⑨ **ENTER:** Press this button to confirm the selection. Press this button together with [-] key to switch output timing to 720p@60 instantly. Press this button together with [+] key to switch output timing to XGA (1024x768) instantly.

6.2 Rear Panel

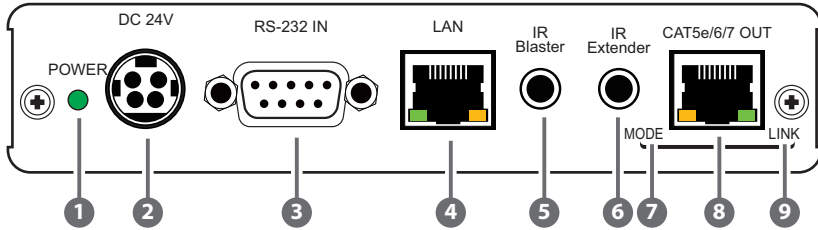

- 1 **Power LED:** This LED will illuminate when the device is connected with power supply.
- 2 **DC 24V:** Plug the 24 V DC power supply into the unit and connect the adaptor to an AC outlet. Only one side of power is needed to activate both Transmitter and Receiver when both obtain the PoE function.
- 3 **RS-232 IN:** Connect to a PC or Laptop with D-Sub 9-pin male cable to bypass RS-232 commands to the Receiver, or for direct RS-232 control of the PU-507TX-HDVGA.
- 4 **LAN:** Connect to an active network for LAN sharing of a total transmission rate up to 100Mbps. Or when a compatible LAN equipped Receiver is connected to an active network, this allows the network access (including internet access if available) to be shared between the Transmitter and Receiver. Connect any Ethernet equipped device e.g. a Smart TV or games console to the LAN port for that device to share the network internet access.

Note: DO NOT connect this slot with any of the CAT5e/6/7 port. Doing so may trigger a power shut down and damage the device.
- 5 **IR Blaster:** Connect to the supplied IR Blaster cable for IR signal transmission. Place the IR Blaster in direct line-of-sight of the equipment to be controlled.
- 6 **IR Extender:** Connect to the supplied IR Receiver cables for IR signal reception. Ensure that remote being used is within the direct line-of-sight of the IR Extender.
- 7 **MODE LED:** This LED will illuminated when the power is connected.
- 8 **Link LED:** This LED will illuminate when the slot has been connected to the Receiver and the Receiver has connected with display that shows image on screen.
- 9 **CAT5e/6/7 Out:** Connect to the Receiver unit with a single CAT5e/6/7 cable for transmission of all data signals.

6.3 Remote Control

- 1 **INPUT:** Press this button to switch HDMI/PC input source instantly.
- 2 **EXIT:** Press this button to exit the menu or escape the current selection under OSD.
- 3 **MENU:** Press this button to enter into the OSD menu.
- 4 **RESET:** Press this button to set the device back into the factory default setting.
- 5 **AUTO ADJUST:** Press this button to optimise the positioning of the picture (picture centering) on the screen.
- 6 **ENTER (OK) & ▲ ▼ ◀ ▶:** Press Enter to confirm the selection or press the arrow buttons to scroll in the OSD selections.

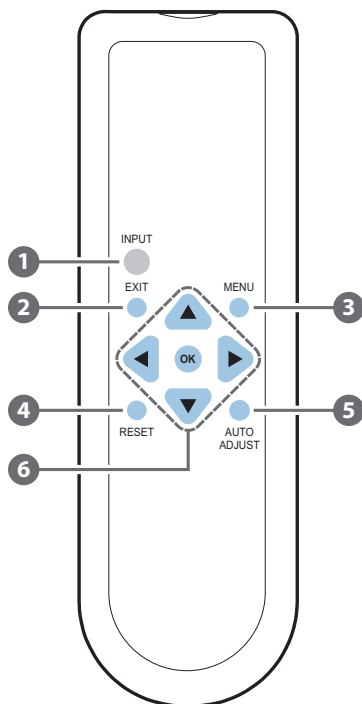

6.4 RS-232 Pin Definitions

PIN	DEFINE TX / RX
1	N/C
2	TxD/RxD
3	RxD/TxD
4	NC
5	GND
6	NC
7	NC
8	NC
9	NC

Baud Rate: 9600 bps

Data Bit: 8-bit

Parity: None

Stop Bit: 1-bit

Flow Control: None

6.5 IR Cable Pin Assignment

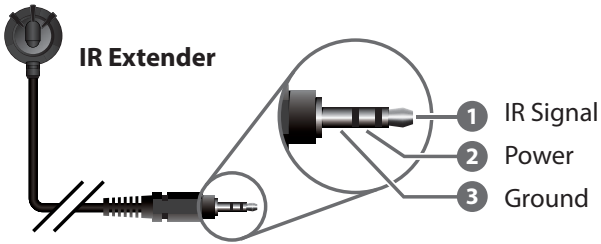
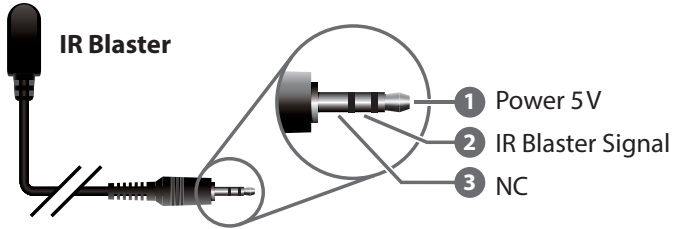

6.6 RS-232 Commands

COMMAND		DESCRIPTION
S SOURCE 1~2	1=PC 2=HDMI	
R SOURCE	Reports the numerical equivalent for SOURCE setting (as above)	
S OUTPUT 0~25	0=Native 1=640×480 2=800×600 3=1024×768 5=1360×768 6=1280×720 7=1280×800 8=1280×1024 9=1440×900 10=1400×1050 11=1680×1050	12=1600×1200 13=1920×1080 16=1920×1200 17=480p 18=720p@60 19=1080p@60 20=1080i@60 22=576p 23=720p@50 24=1080p@50 25=1080i@50
R OUTPUT	Reports the numerical equivalent for OUTPUT setting (as above)	
S SIZE 0~6	0=OVERSCAN 1=FULL 2=BEST FIT 3=PAN SCAN	4=LETTER BOX 5=UNDER 2 6=UNDER 1
R SIZE	Reports the numerical equivalent for SIZE setting (as above)	
S SYNCSHIFT 0/1	0=OFF	1=ON
R SYNCSHIFT	Reports the numerical equivalent for Syncshift setting	
S CONTRAST 0~60	Sets up the numerical equivalent for CONTRAST setting (as left)	
R CONTRAST	Reports the numerical equivalent for CONTRAST setting	
S BRIGHTNESS 0~60	Sets up the numerical equivalent for BRIGHTNESS setting (as left)	
R BRIGHTNESS	Reports the numerical equivalent for BRIGHTNESS setting	
S HUE 0~60	Sets up the numerical equivalent for HUE setting (as left)	

6.7 OSD Menu

1st Layer	2nd layer	3rd Layer	4th Layer
DISPLAY	OUTPUT	Native	
		640x480 60	
		800x600 60	
		1024x768 60	
		1360x768 60	
		1280x720 60	
		1280x800 60	
		1280x1024 60	
		1440x900 60	
		1400x1050 60	
		1680x1050 60	
		1600x1200 60	
		1920x1080 60	
		1920x1200 60	
		720x480p 60	
		1280x720p 60	
		1920x1080i 60	
		1920x1080p 60	
		720x576p 50	
		1280x720p 50	
1920x1080i 50			
1920x1080p 50			

1st Layer	2nd layer	3rd Layer	4th Layer	
DISPLAY (Cont.)	SIZE	OVER SCAN		
		FULL		
		ASPECT RATIO		
		PAN SCAN		
		LETTER BOX		
		UNDER 2		
		UNDER 1		
	MODE INFO	INFO		
		ON		
		OFF		
	PC PC mode only		AUTO SETUP	No
				YES
			H_POSITION	0~60 (30)
			V_POSITION	0~60 (30)
			PHASE	
			CLOCK	
			WXGA/XGA	XGA
				WXGA
			RESET	NO
				YES
TIMING SHIFT	OFF			
	ON			
Colour	COLOR	R		
		G		
		B		
		R OFFSET		
		G OFFSET		
		B OFFSET		

1st Layer	2nd layer	3rd Layer	4th Layer	
COLOR	CONTRAST	0~60		
	BRIGHTNESS	0~60		
	HUE	0~60		
	SATURATION	0~60		
	SHARPNESS	0~30		
	NR.	OFF		
		LOW		
MIDDLE				
HIGH				
AUDIO	VOLUME	0~100		
	DELAY	off		
		40ms		
		110ms		
		150ms		
	SOUND	ON		
		MUTE		
SETUP	FACTORY RESET	NO		
		YES		
	KEY LOCK	OFF		
		ON		
	AUTO SCAN	OFF		
		ON		
INFORMATION	INPUT			
	OUTPUT			
	REVISION			

Note: Items in **Bold** are the Factory default settings. Items in brackets are default values.

6.8 Input Resolution Support

INPUT RESOLUTION	HDMI	PC
NTSC/PAL	-	-
VGA@60/72/75 Hz	✓	✓
SVGA@56/60/72/75 Hz	✓	✓
XGA@60/70/75 Hz	✓	✓
SXGA@60/75 Hz	✓	✓
UXGA@60 Hz	✓	✓
1280×800@60 Hz	✓	✓
1680×1050RB@60 Hz	✓	✓
1920×1080@60 Hz	✓	✓
480i/576i	✓	-
480p/576p	✓	-
720p@50/60 Hz	✓	-
1080i@50/60 Hz	✓	-
1080p@50/60 Hz	✓	-

7. CONNECTION DIAGRAM

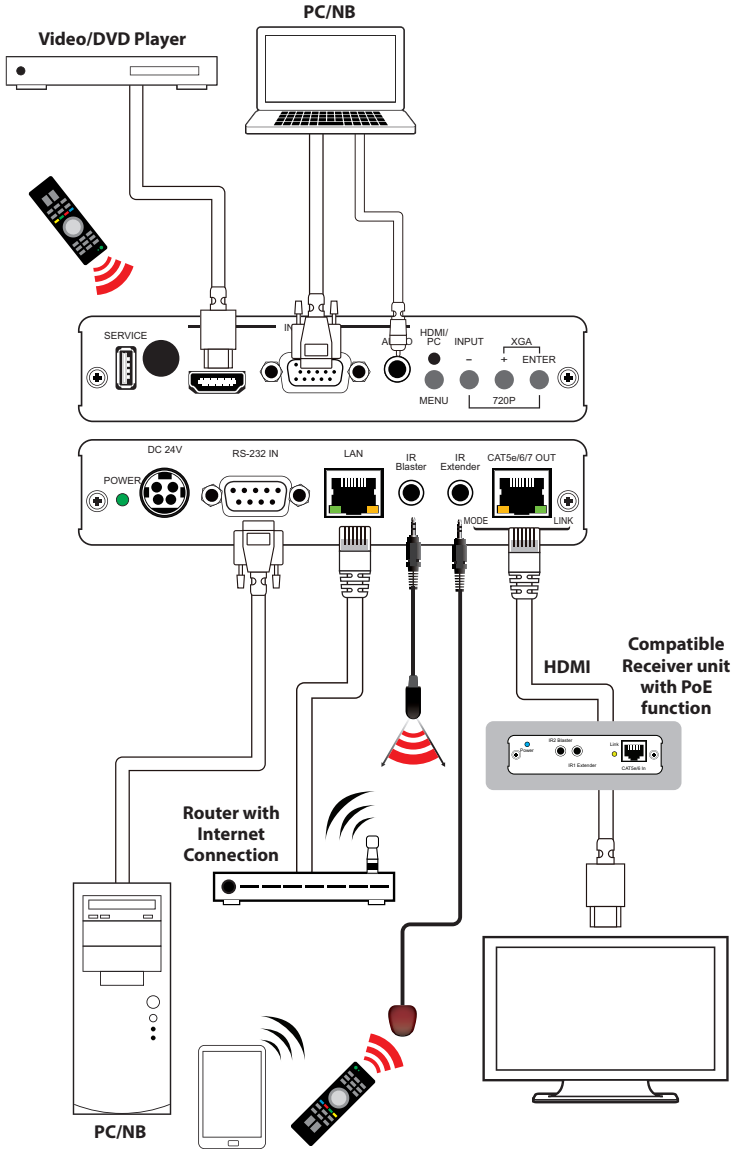

8. SPECIFICATIONS

Output Video Bandwidth	300MHz / 10.2Gbps
Ethernet Speed	100 Mbps
Input Ports	1×HDMI, 1×PC, 1 x 3.5mm Phone Jack (L/R) , 1×RS-232, 1×LAN, 1×IR Extender
Output Ports	1CAT5e/6, 1×IR Blaster
CAT5e/6/7 Output Cable Distance	Up to 100 Metres
Supports Resolution	HD: 480i~1080p PC: VGA ~ WUXGA(RB)
CAT5e/6/7 Output Resolution	HD: Up to 1080p@60Hz PC: Up to WUXGA(RB)
IR Frequency	30~50kHz
Power Supply	24V/2.7A DC (US/EU standards, CE/FCC/UL certified)
ESD Protection	Human body model: ±8kV (air-gap discharge) ±4kV (contact discharge)
Dimensions (mm)	145 (W)×192 (D)×30(H)/Jacks Excluded 145 (W)×202 (D)×30(H)/Jacks Included
Weight	608g
Chassis Material	Aluminum
Colour	Black
Operating Temperature	0 °C~40 °C / 32 °F~104 °F
Storage Temperature	-20 °C ~ 60 °C / -4 °F ~ 140 °F
Relative Humidity	20 ~ 90 % RH (non-condensing)
Power Consumption	17W

9. ACRONYMS

ACRONYM	COMPLETE TERM
CAT5e	Category 5 Cable
CAT6	Category 6 Cable
CAT7	Category 7 Cable
CV	Composite Video
DVI	Digital Visual Interface
HDMI	High-Definition Multimedia Interface
IR	Infrared
WUXGA (RB)	Widescreen Ultra Extended Graphics Array (Reduce blanking)



CYP (UK) Ltd., Unit 7, Shepperton Business Park, Govett Avenue, Shepperton,
Middlesex, TW17 8BA

Tel: +44 (0) 20 3137 9180 | Fax: +44 (0) 20 3137 6279

Email: sales@cypeurope.com

www.cypeurope.com

v1.07