

NOTES:

1. MATERIALS

1.1 CABLE 2.0: 28AWG
OD=4.5 ± 0.15mm.

CABLE MARKING: USB 2.0 CABLE FULLY RATED 30V 80 ° C
1.2 CONNECTOR: P1: USB A TYPE MALE: SOLDER TYPE,
GOLD FLASH CONTACTS, NICKEL PLATED SHELL.

1.3 P2: USB B TYPE MALE: SOLDER TYPE,
GOLD FLASH CONTACTS, NICKEL PLATED SHELL.

1.4 ALL HOOD: MOLDED BLACK PVC.

2. 100% OPEN AND SHORT TEST.

3. PACKING: 1PCS/PE BAG.

4. ALL MATERIAL BE RoHS COMPLIANT.

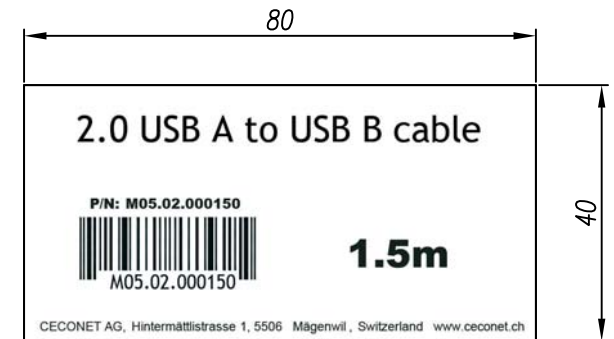
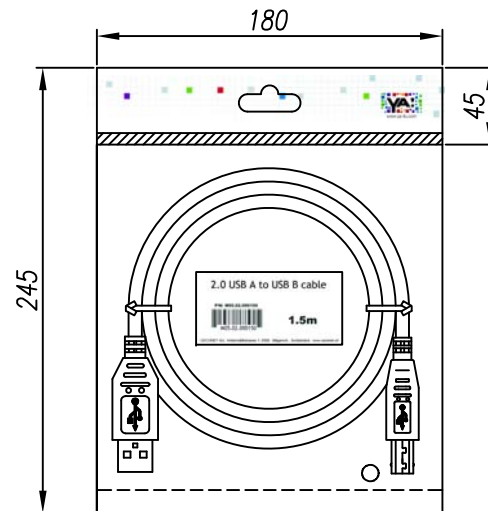

LABEL

TOLERANCE	SCALE	SHEEL	DRAWN BY	DATE
.X	1:1	1 OF 1	Peter	12/05/2017
.XX	REV.	A	CHECKED BY	DATE
ANGLES	MATERIAL	-	THIRD ANGLE PROJECTION	

**2.0 USB A to USB B, cable
male to male, 1.5M**

PART NO.	DWG NO.
M05.02.000150	-

