

USER MANUAL



Video Conference Camera USB2.0 Black AV-CM44-VCUC

www.avonic.com • © September 2022 • Version 1.21

AVONIC

DISCLAIMER, CONTACT, IP RATING, CE MARKING

Disclaimer

All text, graphics, photographs, trademarks, logos, artwork and computer code (collectively, "Content"), including but not limited to the design, structure, selection, coordination, expression, "look and feel" and arrangement of such Content, contained in this Manual is owned, controlled or licensed by or to Avonic, and is protected by trade dress, copyright, patent and trademark laws, and various other intellectual property rights and unfair competition laws.

Except as expressly provided in these Terms of Use, no Content of this Manual may be copied, reproduced, republished, uploaded, posted, publicly displayed, encoded, translated, transmitted or distributed in any way (including "mirroring") to any other computer, server, Website or other medium for publication or distribution or for any commercial enterprise, without the prior written consent of Avonic.

Copyright © 2022 AVONIC All Rights Reserved.

The information contained in this Manual is subject to change without notice.

Contact Info

For any questions or suggestions, contact your reseller or local distributor of Avonic.

Visit the Avonic website www.avonic.com to find your local Avonic distributor or to download the most recent version of the documentation.

Join Avonic on Social Media



www.Facebook.com/avonicPTZ



www.instagram.com/avonicPTZ



www.Linkedin.com/company/avonic



www.youtube.com/channels/avonic



www.twitter.com/avonic

IP Rating

The IP Rating (ingress protection) for this Product is IP30. This means that the Product has an intrusion protection against solid objects over 2.5mm, e.g. tools & wires and has no moisture protection.

CE Marking

The Product has a CE Marking. The CE labels are placed at the bottom of the Product and on the packaging. See the respective figures below:

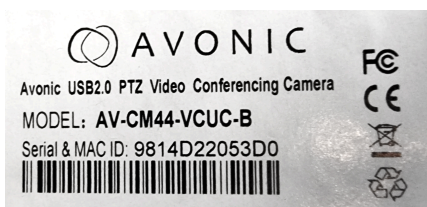

Figure 1: CE Marking (Product)

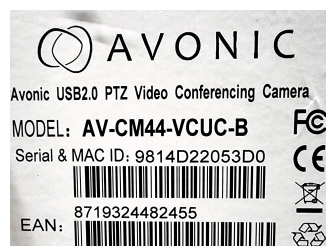

Figure 2: CE Marking (Packaging)

EU DECLARATION OF CONFORMITY

Table 1: EU Declaration of Conformity

	
CE DECLARATION OF CONFORMITY	
1. Models No:	AV-CM44-VCUC-B
2. Brand Name:	Avonic
3. Product Name:	Video Conference Camera USB2.0 Black
4. Manufacturer:	Avonic Exportweg 11a 2645ED Delfgauw The Netherlands
3. This declaration of conformity is issued under the sole responsibility of the manufacturer	
4. The object of the declaration described in point 1 is in conformity with the EMC2014/30/EU	
5. Standards	EN 55032: 2015 EN 61000-3-2: 2014 EN 61000-3-3: 2013 EN 55024: 2010+A1: 2015
6. Signed for and on behalf of Avonic:	
Delfgauw, 25th of April, 2019	
	
Martijn van Bodegom, Product Manager	

IMPORTANT INFORMATION

Liability

Avonic will NOT be held responsible for any damage or injury caused by unqualified persons carrying out these tasks, or by not following the instructions in this Manual.

Intended Use and Non-Intended Use

Installation



The following applies to the **installation** of the camera:

- The installation activities described in this Manual should ONLY be executed by experienced technicians.
- The installation activities should NOT be executed by minors, mentally disabled persons or other persons not qualified to perform these tasks.





Operation





The following applies to the **operation** of the camera:



- The operational activities described in this Manual should ONLY be executed by people with enough technical knowledge to perform the activities in a safe manner.
- This Product is specifically developed for video conferencing / streaming via internet by companies, institutes and universities. It is NOT meant for private use in the residential area.
- This Product should ONLY be used indoors.
- This Product is NOT a medical device and should NOT be used as a substitute for professional medical judgment. It is NOT designed or intended for use in the diagnosis of disease or other conditions, or in the cure, mitigation, treatment, or prevention of any condition or disease. Please consult your healthcare provider prior to making any decisions related to your health.

Important Precautions

	This Product is NOT intended for use where failure of the device could lead to death, personal injury, or severe environmental damage.
	Be sure that you have COMPLETELY READ and UNDERSTOOD ALL information in this Manual before unpacking, installing and using this Product. Keep the Manual in a safe place for future reference or download it from www.avonic.com .
	Failure to follow the SAFETY NOTES as described in this chapter could result in fire, electric shock, injury, or damage to this Product or other property.
	Power this Product ONLY with the included cable and power adapter. Other adapters may not meet applicable safety standards, and could pose a risk of death or injury when connected.

Symbols Used in This Manual

Symbol	Meaning	Description
	Danger	Not following the instructions associated with this symbol may lead to personal injury and / or serious damage to the Product.
	Electrical Shock	Not following the instructions associated with this symbol may lead to life-threatening situations and / or serious damage to the Product.
	Important	The information associated with this symbol requires special attention.

Symbol	Meaning	Description
	Information	The information associated with symbol refers to a general remark or a reference to other documentation.
	Instruction	This symbol refers to one or more user instructions.
	Recycling	Specific parts of the Product can be re-used.

Acronyms

The following acronyms are used in this Manual:

AAE	Aperture Auto Exposure
API	Application Programming Interface
AWB	Aperture White Balance
BLC	Black Light Control
CMOS	Complementary Metal Oxide Semiconductor
DRC	Dynamic Range Compression
EV	Exposure Value
HD	High Definition
HDMI	High-Definition Multimedia Interface
IP	Internet Protocol
MJPEG	Motion-JPEG
NR	Noise Reduction
OSD	On-Screen Display
PoE	Power over Ethernet
PTZ	Pan / Tilt / Zoom
RTMP	Real-Time Messaging Protocol
RTSP	Real-Time Streaming Protocol
SAE	Shutter Auto Exposure
SDI	Serial Digital Interface
SKU	Stock Keeping Unit
SNR	Signal to Noise Ratio
SRT	Secure Reliable Transport
TCP	Transmission Control Protocol
UDP	User Datagram Protocol

Contents

DISCLAIMER, CONTACT, IP RATING, CE MARKING.....	ii
EU DECLARATION OF CONFORMITY.....	iii
IMPORTANT INFORMATION.....	iv
Liability.....	iv
Intended Use and Non-Intended Use.....	iv
Installation.....	iv
Operation.....	iv
Important Precautions.....	iv
Symbols Used in This Manual.....	iv
Acronyms.....	v
INTRODUCTION.....	9
Purpose of This Manual.....	9
Target Audience.....	9
Document Structure.....	9
SAFETY INSTRUCTIONS.....	10
Intended Use.....	10
Important Precautions.....	10
Handling.....	10
Mounting.....	10
Ventilation.....	10
Repair.....	11
Power and Adapter.....	11
Atmospheric Conditions.....	11
PRODUCT OVERVIEW.....	12
UNPACKING.....	13
Package Contents.....	13
Handling Precautions.....	13
Unpacking the Camera.....	14
Return Procedure.....	14
MOUNTING AND INSTALLATION.....	15
Mounting on Wall or Ceiling.....	15
Connecting the Components to the Camera.....	16
Connecting a Controller to a Camera.....	16
Connecting via USB.....	16
Serial Connecting via RS-232 or RS-485.....	17
Connecting via LAN.....	18
OPERATION.....	20
Using the Remote Control.....	20
a. Power.....	21
b. Set.....	21
c. Camera Select.....	21
d. Number Keys.....	21
e. Focus + -.....	21
f. Auto/Manual Focus.....	22
g. Zoom + -.....	22
h. Set & Clear Preset.....	22
i. PTZ Keys (up/down/left/right).....	22
j. Home.....	22
k. BLC ON/OFF.....	22
l. Menu.....	22
m. Function Keys (F1/F2/F3/F4).....	22

n. Blank Buttons.....	22
Other Key Combinations.....	23
Using the System Select.....	23
OSD Menu.....	24
1. MENU.....	25
2. SETUP.....	25
3. CAMERA.....	25
3.1 EXPOSURE.....	26
3.2 COLOR.....	28
3.3 IMAGE.....	29
3.4 FOCUS.....	29
3.5 NOISE REDUCTION.....	30
3.6 STYLE.....	31
4. PTZ.....	31
5. NETWORK SETTINGS.....	32
6. VERSION.....	32
7. RESTORE DEFAULT.....	32
WebGUI.....	33
Login.....	33
NETWORK.....	33
SYSTEM.....	34
MAINTENANCE.....	37
Camera Maintenance.....	37
Usage Precautions.....	37
TRANSPORT AND STORAGE.....	38
DISPOSAL AND RECYCLING.....	39
TROUBLESHOOTING.....	40
General.....	40
Power Issues.....	40
Image.....	40
No image.....	40
Abnormal image.....	40
Dithering or flickering image.....	40
Color issues.....	40
Autofocus Issues.....	40
Control.....	41
No self-test (PTZ cameras only) and no power LED.....	41
Remote Controller does not work.....	41
WebGUI.....	41
Cannot enter WebGUI.....	41
Firmware update failed.....	41
APPENDIX A - VISCA SETTINGS AND COMMAND LIST.....	42
VISCA over Serial Connection.....	42
VISCA over IP.....	42
VISCA over IP using the full Sony VISCA protocol.....	44
Camera Return Commands.....	45
Camera Control Commands.....	46
Inquiry Commands.....	52
Appendix A1 - Pelco-D Protocol and command List.....	56
Appendix A2 - Pelco-P Protocol and command List.....	57
APPENDIX B - DIMENSIONS.....	58
APPENDIX C - HTTP API.....	59
How to use HTTP API.....	59
Curl.....	60

{"GetEnv"}.....	61
HTTP API code list.....	62
IR Remote Control.....	62
PTZ.....	62
Audio.....	64
Video.....	65
Network.....	69
System.....	70
APPENDIX D - CMOS SENSOR CHARACTERISTICS.....	72
APPENDIX E - DATASHEET SPECIFICATIONS.....	73
SPECIFICATIONS.....	73
Index.....	74

INTRODUCTION

Purpose of This Manual

This Manual describes the safety precautions and the instructions for safe unpackaging, installation, operation, maintenance and disposal of the Avonic CM44 camera.



In this Manual the Avonic CM44 camera is referred to as the 'Product'.

Target Audience

This Manual is developed for installation technicians who install the Product at client sites, and for IT professionals who are responsible for operating the Product.

Document Structure

The Manual is subdivided into the following **Chapters**:

1. Introduction
2. Safety Instructions
3. Product Overview
4. Unpacking
5. Mounting and Installation
6. Operation
7. Maintenance
8. Transport and Storage
9. Disposal and Recycling
10. Troubleshooting

Additionally, it contains the following

- Appendix A - VISCA Settings and Command List
 - Appendix A1 - Pelco-d Protocol and command List
 - Appendix A2 - Pelco-p Protocol and command List
- Appendix B - Dimensions
- Appendix C - HTTP API
- Appendix D - CMOS Image Sensor Characteristics
- Appendix E - Datasheet Specifications

SAFETY INSTRUCTIONS





This chapter contains important safety information regarding the unpacking, installation and use of the camera.

Intended Use



See section [Intended Use and Non-Intended Use](#) on page iv for details.

Important Precautions

	This Product is NOT intended for use where failure of the device could lead to death, personal injury, or severe environmental damage.
	Be sure that you have COMPLETELY READ and UNDERSTOOD ALL information in this Manual before unpacking, installing and using this Product. Keep the Manual in a safe place for future reference or download it from www.avonic.com .
	Failure to follow the SAFETY NOTES as described in this chapter could result in fire, electric shock, injury, or damage to this Product or other property.
	Power this Product ONLY with the included cable and power adapter. Other adapters may not meet applicable safety standards, and could pose a risk of death or injury when connected.

Handling



To prevent the risk of injury, take the following precautions when handling this Product:

- Handle the Product with care. It is made of metal, glass, and plastic and has sensitive electronic components inside.
- The Product can be damaged if dropped, burned, punctured or crushed, or if it comes into contact with liquid.
- Do not pick up and move the Product unit while a tripod is attached. The fitting may break under the weight of the tripod, which may result in injury.
- If you suspect any damage to the Product, discontinue its use, as it may cause overheating or injury.

Mounting



To prevent the Product from falling down which may cause injuries:

- Set up this Product on a hard, stable surface or mount it to a wall or ceiling.
- ONLY use an Avonic mount for mounting to a wall or ceiling.
- Ensure the mounting construction is capable of supporting four times the weight of the Product. (See 'General Specifications > Weight product' in the Product Datasheet for the exact weight.)
- Use a safety loop or drop protection that prevents the Product from falling if the mounting construction fails.
- During installation, NEVER install a Product above a person.
- Check the installation at least once a year. An improper mounting could cause the unit to fall off, resulting in personal injury.

Ventilation



To prevent the risk of life-threatening injury or damage to the Product or other property, caused by electric shock or fire hazard due to overheating:

- Maintain adequate ventilation by NOT installing or placing the Product unit in a bookcase, built-in cabinet or any other confined space.
- Ensure that curtains or any other material does NOT obstruct the ventilation.

Repair



Take the following precautions if the Product should be repaired:

- Don't open this Product and don't attempt to repair it yourself. Disassembling the Product may damage it or may cause injury to you.
- If this Product is damaged, malfunctioning, or if it comes into contact with liquid, contact Avonic or an Avonic Authorized Service Provider.
- Repairs by service providers other than Avonic or an Avonic Authorized Service Provider may not involve the use of Avonic genuine parts and may affect the safety and functionality of the device. You can find more information about repairs and service at www.avonic.com.

Power and Adapter



To prevent the risk of life-threatening injury or damage to the Product or other property, caused by electric shock or fire hazard:

- Power this Product ONLY with the included cable and power adapter. Other adapters may not meet the applicable safety standards. They could pose a risk of death or injury when connected.
- Do NOT use damaged cables.
- Do NOT power the Product in a moist / wet environment.
- Before you power the Product, ensure the cable is fully inserted into the power adapter.
- Plug the power adapter directly into a power outlet.
- Do NOT use the power adapter at a moist / wet location.
- Do NOT connector disconnect the power adapter with wet hands.
- Keep the Product, cable, and power adapter in a dry and well-ventilated area when in use.
- Stop using the power adapter and any cables if any of the following conditions exist:
 - The power adapter plug or prongs are damaged.
 - The cable becomes frayed or otherwise damaged.
 - The power adapter is exposed to excessive moisture, or liquid is spilled into it.
 - The power adapter has been dropped, and its enclosure is damaged.

Atmospheric Conditions



To prevent the risk of injury or damage to the Product or other property caused by a potentially explosive atmosphere:

- Do NOT use this Product in an area with a potentially explosive atmosphere, such as areas where the air contains high levels of flammable chemicals, vapors, or particles (such as grain, dust, or metal powders), may be hazardous.
- Exposing this Product to environments having high concentrations of industrial chemicals, including near evaporating liquified gasses such as helium, may damage or impair this Product functionality.
- Obey all signs and instructions.

PRODUCT OVERVIEW

Description

The Avonic AV-CM44-VCUC is a high-quality USB video conferencing PTZ camera with IP-control and a discrete design. The CM44-VCUC, with its versatile horizontal FOV of 83.7° and flexible 5x optical zoom range, is suitable for small to medium size meeting rooms.

This easy to use USB video conference camera has a plug-and-play design and can easily be controlled with the handheld IR remote. The camera has extremely silent mechanical Pan/Tilt/Zoom and can either be mounted on the wall or the ceiling. Due to the high SNR CMOS sensor in the CM44-VCUC it's possible to obtain a pristine video quality even under low light conditions, making it ideal for every conference room. Easily create high-quality video that feels like you are together in the same room.



Features

The Avonic CM44 camera has the following features:

Lens

High-quality wide-angle glass lens, 5x optical zoom and 83.7° horizontal field of view.

Low light

High SNR CMOS combined with digital noise reduction, the picture is clear even under low illumination (0.5 lux @ F1.8) conditions.

Full HD 1080p30

With 1/2.8" high-quality CMOS sensor (2.07 Megapixel) the camera has a resolution of 1920 x 1080p30 and achieves a picture of great quality.

Output

USB 2.0 up to 1080p30.

Control

Control the camera with common protocols: VISCA over IP (RJ45), Visca and Pelco-D/P (RS232/ RS485) or IR remote control (included).

Presets

Up to 255 presets with 0.1° accuracy.

UNPACKING

This describes the contents of a complete Product package, and instructions for safe unpacking and (if necessary) Product return.

It is subdivided into the following sections:

1. Package Contents
2. Handling Precautions
3. Unpacking the Camera
4. Return Procedure

Package Contents

The following tables contains an overview of the package contents of the Product.

No.	Quantity	Description	Avonic SKU
1	1 pc	PTZ Camera	AV-CM44-VCUC
2	1 pc	Remote Control	AV-CM40-RC
3	1 pc	USB cable type A to type A	AV-USB20-AA
4	1 pc	Power Adapter 12V/A	AV-CM40-PSU
5	1 pc	RS-232 9-pin D-Sub female to DIN -8 male	AV-CM-RS-232
6	1 pc	RS-485 2-pin Phoenix Connector	AV-PHNX-2

Each item is visualized below and referenced by the associated number in the table above:



Figure 3: Package Contents

Handling Precautions



Always take the camera by its base and do **not** move the position of the lens manually. See below.

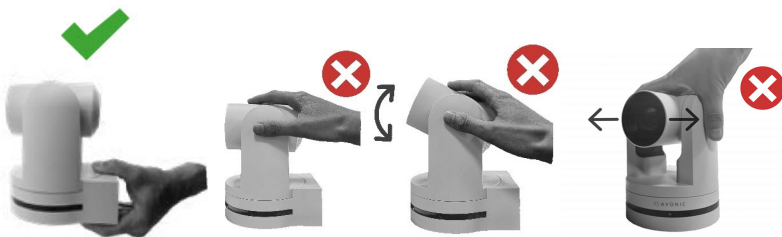

Figure 4: Handling Precautions

Unpacking the Camera

 Execute the following steps to unpack the camera and associated components:

1. Open the box.
2. Verify that the contents of the box exactly matches the items as described in [Package Contents](#). If this is NOT the case, contact Avonic and stop here.

The camera should be in its protective foam as follows:



Figure 5: Camera in Foam

3. Verify that the plastic camera bag is sealed. If this is NOT the case, contact Avonic and stop here.
4. Break the seal of the sealed camera bag.
5. Take the camera out of the bag. Be sure to follow the [Handling Precautions](#) on page 13 while doing so.
6. Install the camera following the steps as described in chapter [MOUNTING AND INSTALLATION](#) on page 15

Return Procedure

 If, for any reason, you have to return the camera to Avonic, Execute the following steps:

1. Place the camera back in its protective foam. **Verify that the lens is in HORIZONTAL position!**
2. Place the camera with **all** of its components in the box.
3. Verify that the contents of the box **exactly** matches the items as described in [Package Contents](#).
4. Contact Avonic for the Return Procedure.

MOUNTING AND INSTALLATION

This chapter describes the steps you have to perform to mount and install the Product in a correct and safe manner.

These steps are subdivided into the following groups, each of which is described in a separate section:

1. Mounting on Wall or Ceiling
2. Connecting the Components to the Camera
3. Connecting a Controller to a Camera



Take the following precautions to prevent the Product from falling down which may cause injuries:

- Set up this Product on a hard, stable surface, or mount it to a wall or ceiling.
- ONLY use an Avonic mount for mounting to a wall or ceiling.
- Ensure the mounting construction is capable of supporting four times the weight of the Product. (See 'General Specifications > Weight product' in the Product Datasheet for the exact weight.)
- Use a safety loop or drop protection that prevents the Product from falling if the mounting construction fails.
- During mounting and installation, NEVER install a Product above a person.
- Check the installation at least once a year. An improper mounting could cause the unit to fall off, resulting in personal injury.

Mounting on Wall or Ceiling

The following accessories (AV-MT200 and AV-MT250) are separately available if the client wants to mount the camera to the wall or ceiling. Contact your Avonic reseller or local distributor for purchasing details.



Wall and Ceiling mount (AV-MT200)

SKU white: AV-MT200-W

SKU black: AV-MT200-B



Ceiling mount (AV-MT250)

SKU white: AV-MT250-W

SKU black: AV-MT250-B



Visit www.avonic.com to download instructions for mounting the camera to the wall or ceiling using the accessories AV-MT200 or AV-MT250.

Connecting the Components to the Camera

Execute the following steps to connect the components to the camera:

1. Connect all provided components (see [Package Contents](#)) to the ports at the back of the camera. The figure below shows the applicable ports.



2. If you connected the power cable to the camera, set the power switch at the back of the camera to 'ON'. After empowering the camera, it starts initializing by first rotating the Pan-Tilt to the maximum top right position and then to the center.

If position preset '0' has been stored, this is the position that will be called after initialization.

The current IR-channel setting and IP Address of the camera are displayed on the [OSD Menu](#). From this point onwards, the user can start controlling the camera.

Connecting a Controller to a Camera

You can connect one or more cameras to an VISCA IP controller.

See <https://avonic.com/en/product-categorie/controllers/> for an overview of the available controllers.

A controller gives you direct control over the most important camera settings (e.g., Pan, Tilt, Zoom, Focus, White Balance). You can access all other settings through the **OSD Menu** of the camera using the controller. The camera(s) can be connected via a serial connection to USB, RS-232, RS-485, or via a LAN Ethernet connection. Each of these options is described below.

Connecting via USB

Execute the following steps to connect the camera to a desktop or a (computer) monitor via USB2.0:

1. Connect the camera to the desktop or monitor via the USB2.0 port (see figure above).
2. Open the Windows Camera app or a third-party camera app and open the settings.
3. Select the camera, or click on the option / icon to change the camera to the camera you just connected.
4. Press the **MENU** button on the provided IR Remote Control to open the **OSD Menu**.

See [Using the Remote Control](#) for more information on how to use the Remote Control.

Serial Connecting via RS-232 or RS-485

COM Port Settings

In default working mode, the camera can connect to a VISCA controller via a RS-232 or RS-485 serial interface. The applicable COM port settings are (where '*' stands for 'Default value'):

RS-232

- Baud rate: 2400/4800/9600*/115200
- Start bit: 1 bit
- Data bit: 8 bits
- Stop bit: 1 bit

RS-485 (half-duplex mode)

- Baud rate: 2400/4800/9600*
- Start bit: 1 bit
- Data bit: 8 bits
- Stop bit: 1 bit



See [Appendix A - VISCA Settings and Command List](#) for the command list.

RS-232 Interface

The controller can be connected to the back of the camera via the RS-232 cables as shown below:

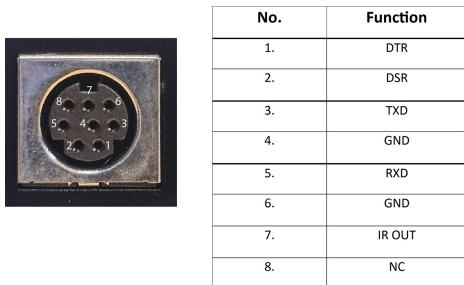

Figure 7: RS-232 Interface (Mini DIN-8)

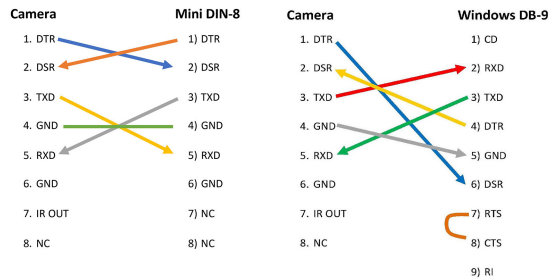

Figure 8: RS-232 Cable and Interface Connection (Mini DIN-8 and Windows DB-9)

RS-232 Network Connection



Execute the following steps to connect the controller to the back of the camera(s) via RS-232:

1. Make a connection using **daisy chaining** network architecture. The max cable length is 10-15m.

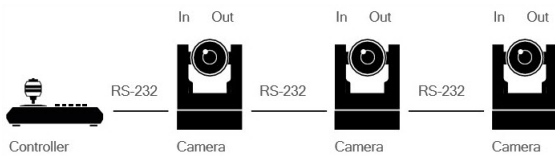

Figure 9: RS-232 Network Connection Diagram

RS-485 Interface



Connect the controller to the + and - at the back of the camera via the RS-485 cables, as shown in the figure below. Note that the color of the connecting cables (red and black in the figure) may vary.



Figure 10: RS-485 Interface

RS-485 Network Connection



Execute the following steps to connect multiple cameras to RS-485:

1. Attach the cameras to a 2-wire twisted pair bus (maximum length 1200m) that is terminated at both ends with a 120Ω-impedance resistor.
2. Ensure that the maximum distance from the bus to the camera or controller is 5m. If you use only ONE camera, the impedance resistor is not needed.

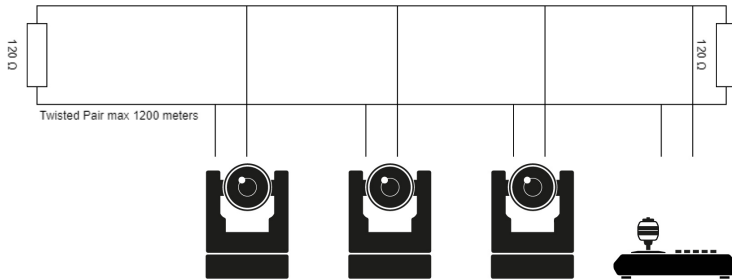

Figure 11: RS-485 Network Connection Diagram

Connecting via LAN

Avonic cameras can be controlled by any device using a LAN and a standard switch.

Settings

By default, the IP address of the camera is "192.168.5.163" with "admin" for both the username and password.

The control parameters for the CM4x cameras are as follows:

- IP Address: 192.168.5.163
- Username: admin
- Password: admin
- TCP or UDP port: 1259

IP (Network) Connection



Execute the following steps an Avonic camera to a LAN:

1. Use a standard switch.
2. Ensure that addressing is done via IP. When using VISCA over IP, the 'x' in all the '8x' addresses is always '1', where the Visca address in a Visca over IP environment is always 1. (See [Appendix A - VISCA Settings and Command List](#) for more information.)

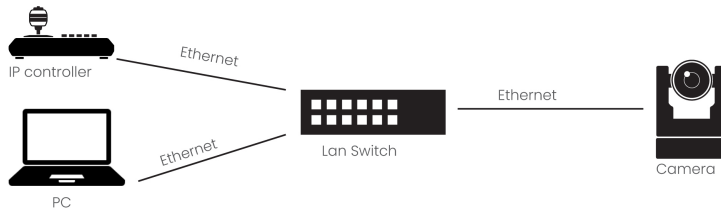

Figure 12: IP Network Connection Diagram

OPERATION

This chapter describes the ways in which you can set up and operate the Product. The descriptions are subdivided into the following sections:

1. Using the Remote Control
2. Other Key Combinations
3. OSD Menu
4. Using the Select Switch
5. WebGUI

Using the Remote Control

The Product is provided with an IR Remote Control for full control of the camera and use of the OSD menu.



Figure 13: Remote Control

The various options (a. through n.) are described below.

a. Power



1. Put two AAA 1.5v batteries in the IR Remote Control.
2. Press the **Power** button to turn on the camera. If the position preset '0' has been stored, this will be called after initialization.
3. Press the **Power** button again to turn the camera off. It will turn to the back when turned off, this is called the "privacy mode".

b. Set

This button has **no** function with this camera.

c. Camera Select

Up to 4 different cameras can be controlled with one IR remote Control. You can use the **camera select** buttons [1,2,3,4] to select the IR channel that the remote control is using. The default camera IR channel is 1.



1. To control a camera on first use, select camera 1 (IR channel 1) on the remote control.
2. To control a second camera, you first need to change the IR channel stored in the camera from 1 to 2. Then do the following:
 - a. First turn off the other cameras in the room you don't want to change, to prevent that other cameras also get changed accidentally.
 - b. Select camera 1 on the remote control, because the camera is still configured to listen to IR channel 1.
 - c. Press [*]→[#]→[F2] to change the IR channel inside the camera to IR channel 2. The camera will confirm this on the screen.
 - d. Select camera 2 on the remote control to control this camera.

Key Combinations: (Default IR address is 1)

[*]→[#]→[F1]	Camera Address No. 1
[*]→[#]→[F2]	Camera Address No. 2
[*]→[#]→[F3]	Camera Address No. 3
[*]→[#]→[F4]	Camera Address No. 4



The Function buttons F1, F2, F3 and F4 are the colored buttons on the remote.

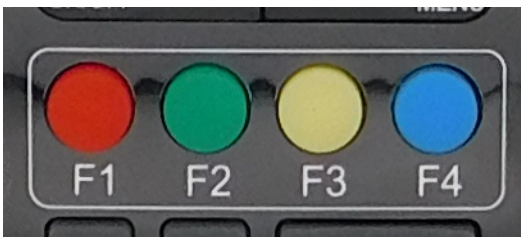

Figure 14: Function Buttons on Remote

d. Number Keys

The number keys are used to call presets.



Press the number [0-9] of the desired preset and the camera will respond accordingly (See 'h' on how to set & clear presets).

e. Focus + -



1. Push the button [manual focus] first before using the focus buttons.
2. Focus the camera with the [+] and [-] button.
If the camera does not respond, check if the camera is set to auto-focus.

f. Auto/Manual Focus



Set the camera to 'auto focus' or 'manual focus'.

If the camera is configured to 'auto focus', the buttons [Focus + -] are disabled.

If the camera is in 'manual focus' and the **Zoom** buttons are used, the camera automatically switches to 'auto focus'.

g. Zoom + -



Zoom the camera with these buttons.

h. Set & Clear Preset

A preset is a specific position of a camera that you save in the camera. A preset is assigned to a number from 0-9.



1. To set a preset, first point the camera in a specific directing and a specific zoom position.
2. Assign the position to a number with the button **Set Preset**.
3. You can call the preset by pressing one of the numbers 0-9 on the remote control.

Set Preset: [SET PRESET]→[<number>]

Call Preset: [<number>]

Clear Preset: [CLEAR PRESET]→[<number>]

If the position preset '0' has been stored, this position will be called after initialization.



Use ONLY presets between 0-9 when using the Remote Control. For presets 10 or higher you need a serial or IP connection!

i. PTZ Keys (up/down/left/right)



Use these keys to move the camera in the desired direction.

j. Home



Use this key to set the direction of the camera to the center position.

k. BLC ON/OFF



Use this key to enable / disable the Back Light Compensation feature.

l. Menu



1. Use the **Menu** button to open the **On Screen Display (OSD)** menu. This menu is visible on the USB and IP output.
2. If the menu is not in English, press [*]→[#]→[4] to change the Menu language into English.

m. Function Keys (F1/F2/F3/F4)

Used to configure the IR channel of the camera. See '**c. Camera Select**' above for instructions.

n. Blank Buttons

These buttons have NO function with this camera.

Other Key Combinations

The following key combinations on the Remote Controller have specific functions. These are:

Combination	Function
[*] → [#] → [4]	Menu set to English
[*] → [#] → [6]	Restore factory defaults
[*] → [#] → [9]	Flip switch (just temporary flip to view the image flipped)
[*] → [#] → [Auto]	Enter into the aging mode, only for quality control purposes
[*] → [#] → [Manual]	Restore the default username, password, and IP address
[#] → [#] → [#]	Clear all presets

 The camera returns to the video output setting of the rotary dial after a reboot.

 **Use ONLY presets between 0-9 when using the Remote Control. For presets 10 or higher you need a serial or IP connection!**

Using the System Select

The back of the Product is provided with a System Select that can be used to select a video format. This System Select is important for the video quality during video recording or streaming.

 The System Select has **NO FUNCTION** in the AV-CM44-VCUC as all the output resolutions are dictated by the computer to which it has been connected.



 After switching the camera to ON, the lens will make a complete rotational cycle to determine the camera's Pan and Tilt endpoints. When the bootcycle has been finished, the lens will face center forwards or to a start-up preset if one has been programmed. The camera will show its current IR-channel setting and IP Address on the OSD Menu.

OSD Menu

Each camera is provided with an **On-Screen Display (OSD) Menu**.

This is an integrated on-screen menu that can be accessed within the camera to change specific functions that effect how the camera processes an image.

The OSD Menu is visible on the USB and IP outputs.

The OSD menu can be accessed by the Remote Control or an Avonic PTZ controller.

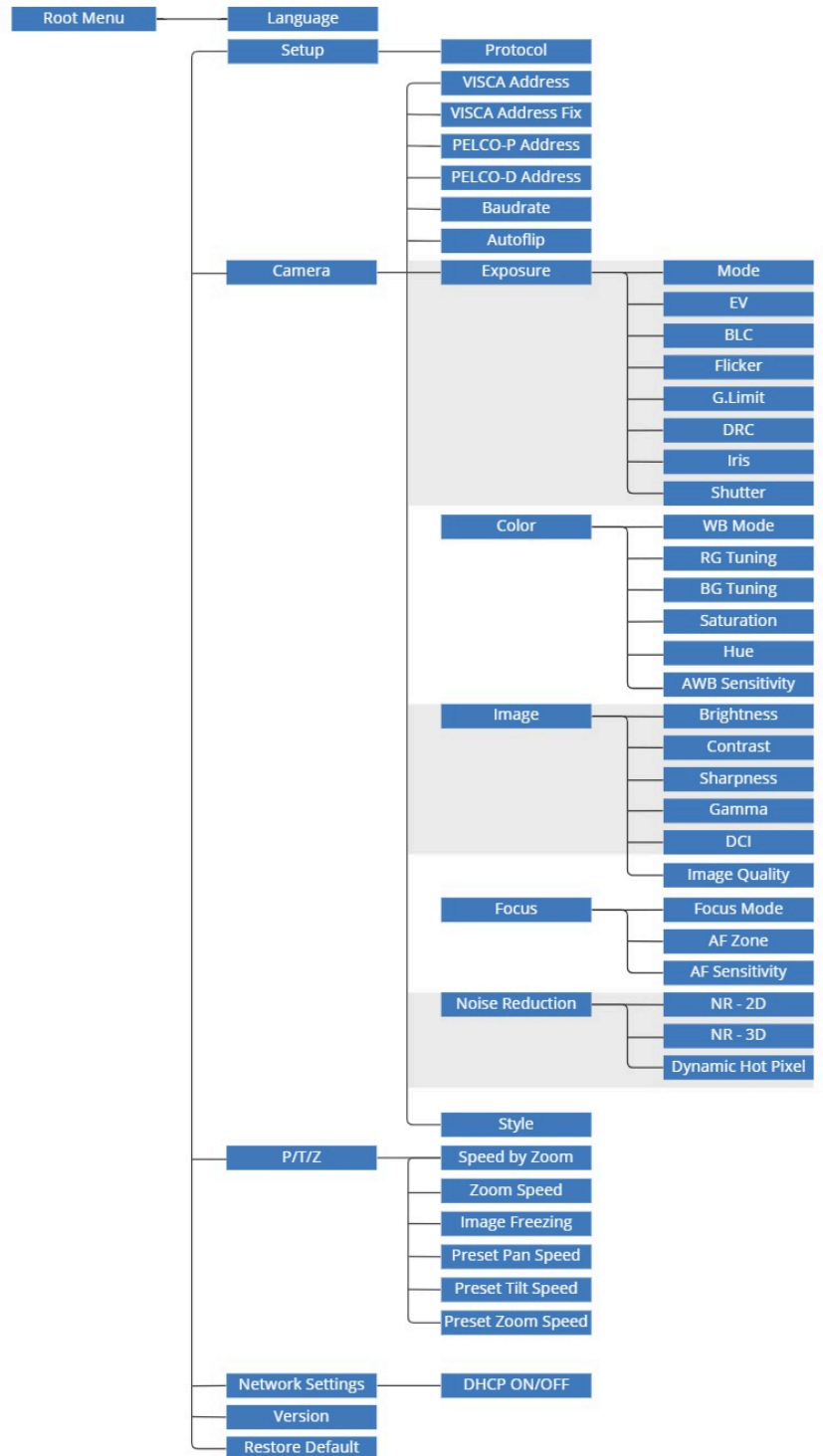

Figure 15: OSD menu structure

1. MENU

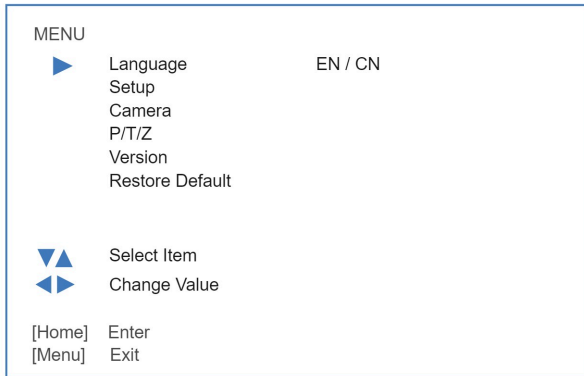

Figure 16: OSD - MENU



1. Press the **[MENU]** button to display the main menu on the screen.
2. Use the arrow buttons to move the cursor to the item to be set. Press the **[HOME]** button to enter the corresponding sub-menu.
3. Press **[◀▶]** to change settings. Press **[MENU]** again to go back.

2. SETUP



Figure 17: OSD - SETUP



1. Select the Protocol you want to use: Auto, VISCA, or PELCO and set the Address. If you are using VISCA, you set the VISCA address. If you are using PELCO-P or D, you set the PELCO address.
2. Set the Baudrate (2400 - 115200).
3. If you want to flip the picture up side down, you can set the Autoflip to "ON".

3. CAMERA

Under camera you can change Exposure, Color, Image, Focus, Noise Reduction and Style settings. In the now following parts these settings will be explained.

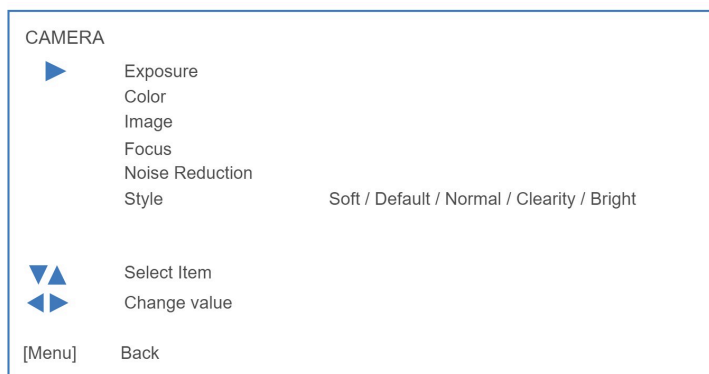

Figure 18: OSD - CAMERA

3.1 EXPOSURE

EXPOSURE	
▶ Mode	Auto / Manual / SAE / AAE / Bright
Iris	F11 ~ F1.8 / Close
Shutter	1/25 ~ 1/10000
EV	ON / OFF
EV Level	-7 ~ +7
BLC	ON / OFF
Flicker	50Hz / 60Hz / OFF
G.Limit	0 ~ 15
DRC	1 ~ 8 / CLOSE
▼▲	Select Item
◀▶	Change value
[Menu]	Back

Figure 19: OSD - EXPOSURE

If you click in the field after the option 'mode', you will see that you have the following Exposure options: **Auto**, **Manual**, **SAE**, **AAE** and **Bright**. These options are described below.

Auto Exposure Mode

In Automatic exposure mode, the camera determines the iris and shutter settings. There are a couple of settings to present the camera with some limits as to what it may do to the image:

EV (Exposure Value): ON/OFF and Level

If the light conditions require this, you can create a quick adjustment to your current exposure settings without actually changing the fundamental values like iris and shutter.



Remember that this is a software setting, take care to not 'overdo' the settings or the picture will become washed out bright or too dark to make out details in shadows.

BLC (Back Light Compensation): ON/OFF

Compensate for having to film against bright lighting directly into the lens. See the pictures below:

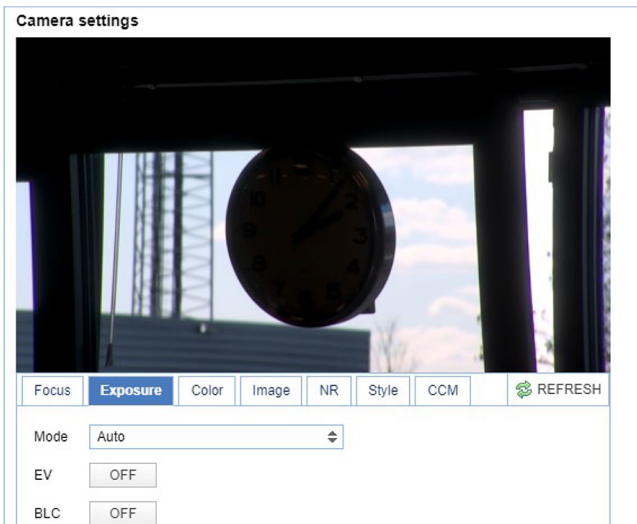

Figure 20: WebGUI > VIDEO > Camera Settings > Auto Expo (BLC OFF)

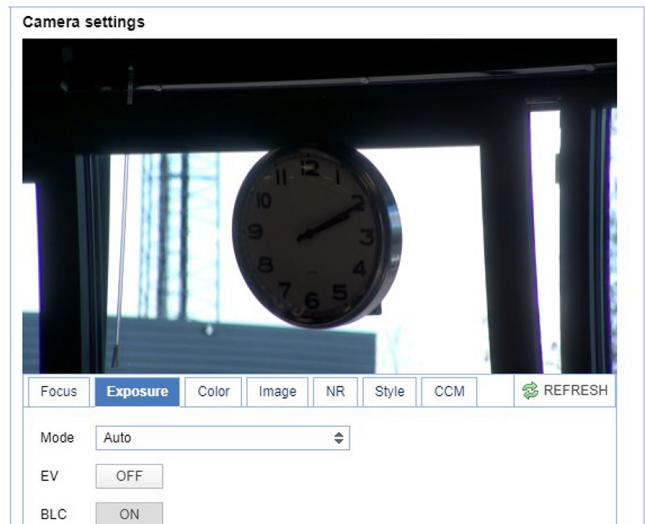

Figure 21: WebGUI > VIDEO > Camera Settings > Auto Expo (BLC ON)

Flicker

Set up your camera so that it can handle the flickering of artificial lighting in the space where it is operating. The options are 50Hz, 60Hz and OFF.

G.Limit

Gain limit is the maximum level of artificial brightness and contrast that the camera can automatically add to the image. This setting will make a significant difference to the overall picture.



Make sure that this setting can add noise to the picture in dark areas and produce a washed out, greyish image. This is done for a reason.

DRC

Dynamic Range Compression has a similar effect on the picture as the above mentioned gain limit. The DRC works by compressing the natural dynamic range of the image by taking out the darkest and lightest parts of the image. This can be a particular helpful setting when the light conditions are challenging. The differences should be clearly visible in dark parts of the image, as they will become lighter/more grey as the level of DRC increases.

Manual Exposure Mode

In Manual exposure mode, you can manually set the shutter, Iris and DRC options.

Shutter

The shutter setting determines the amount of time per second that the sensor is exposed. The range of the shutter speed setting is 1/25th of a second (40 milliseconds) to 1/10000th of a second (0.1 milliseconds).

If you shoot a video with a shutter time of 1/25th of a second, you can imagine that the video becomes blurry and overexposed. The faster the shutter is set to open and close, the sharper your filmed object will become. However, the amount of light that falls onto the sensor is also diminished.



If you are inexperienced or if the light conditions change a lot, it's best practice to keep the camera on the automatic exposure setting.

Iris

The Iris is a part of a lens that regulates the amount of light that passes through the lens and onto the sensor, by altering the diameter of the hole through which the light enters. The diameter of the hole is measured in **F-stop** value. A higher value lets in less light, while a lower setting lets in more light. The Iris setting affects the length of the depth of field. The higher F-stop you use, the deeper your depth of field, and vice versa. Reason: the smaller the aperture, the more focused the light beams will be, resulting in a more focused image.

DRC

Dynamic Range Compression has a similar effect on the picture as the above mentioned gain limit. The DRC works by compressing the natural dynamic range of the image by taking out the darkest and lightest parts of the image. This can be a particular helpful setting when the light conditions are challenging. The differences should be clearly visible in dark parts of the image, as they will become lighter/more grey as the level of DRC increases.

SAE Mode (Shutter Auto Exposure)

In this mode, the shutter speed is user-adjustable. The camera automatically decides the best Iris F-stop value for an optimal exposure setting.



The shutter speed is the amount of time that each frame of the sensor has been exposed to light.

To compensate for poor lighting conditions, it is possible to adjust the [DRC \(Dynamic Range Compression\)](#).

AAE Mode (Aperture Auto Exposure)

The camera will automatically set the shutter speed based on the Iris F-stop value (aperture) set by the user. As the camera determines the preferable shutter speed, it is possible in this mode to turn the anti flicker setting to the required 50Hz or 60Hz to eliminate the effects of a shutter functioning at 1/50th of a second, for example.

In this mode, both the Gain limit and DRC are available to compensate for challenging light conditions.

Bright Mode

This mode is to try and create a decent image when the light conditions are exceptionally poor.

In this mode, you should keep the Bright level, Gain limit and DRC as low as possibly acceptable to avoid getting too much noise in the picture. If the level of noise in the image becomes unacceptable, you can use [noise reduction](#) to smooth the picture over.

3.2 COLOR

The color modes inside the camera are designed in such a way that the video output of the camera can match the current light conditions to produce accurate colors. There are several automatic preset modes and a manual mode to set the colors to the preference of the user.

COLOR	
▶	WB Mode Auto / 3000K / 4000K / 5000K / 6000K / 7000K / Manual / OnePush
	RG Tuning -10 ~ 10
	BG Tuning -10 ~ 10
	RG 0 ~ 255
	BG 0 ~ 255
	Saturation 60% ~ 200%
	Hue 0 ~ 14
	AWB Sensitivity Low / Middle / High
▲▼	Select Item
◀▶	Change Value
[Menu]	Back

Figure 22: OSD - COLOR

The settings are listed below.

WB mode auto	The camera continuously measures and defines the light conditions and acts accordingly. In this mode, there are some adjustments that can be made to tune the image to the preference of the user.
RG Tuning	Red Gain Tuning, increase or decrease red.
BG Tuning	Blue Gain Tuning, increase or decrease blue.
RG	Finetuning the color red.
BG	Finetuning the color blue.
Saturation	How saturated the image's colors are. 0% would produce a black and white image.
Hue or tint	The balance between green and red. 0 is green, 14 is red.
AWB Sensitivity	This setting indicates how quickly the camera responds to changing light settings.

3.3 IMAGE

IMAGE	
▶	Brightness 0 ~ 14
	Contrast 0 ~ 14
	Sharpness 0 ~ 15
	B&W Mode Color / B&W
	Gamma 0.45 / 0.50 / 0.55 / 0.63 / Default
	DCI 1 ~ 8 / Close
	Image Quality 0 ~ 5
▼▲	Select Item
◀▶	Change Value
[Menu]	Back

Figure 23: OSD - IMAGE

These are settings that have an effect on the image post-processing. Basically, these settings are all artificial: they don't affect the optical parts of the camera itself.

The settings are listed below.

Brightness	The amount of detail that is visible in darker areas of the image. Be careful not to set this setting too high, as you will see that the image becomes 'milky-white'.
Contrast	The amount of detail that is visible in lighter areas of the image.
Sharpness	Artificial contrast, be careful no to set this too high as it will create a sort of 'halo' around sharp edges of filmed objects. The setting of sharpness coincides with the setting of noise reduction.
B&W Mode	Black and White Mode makes the picture black and white.
Gamma	The gamma curve selection has to do with the perception of the human eye to lighter and darker. If you select a higher rate of gamma, you will see that the picture become darker, but you get also more detail.
DCI	The Dynamic Contrast affects the contrast of the picture. The higher the number, the more contrast you will get.
Image Quality	Improves the image quality by making the picture slightly more saturated.

3.4 FOCUS

FOCUS	
▶	Focus Mode Auto / Manual / OnePush
	AF-Zone Front Focus / Back Focus / Meeting / Education Tracking / Moving Objects / Center Focus
	AF-Sensitivity Low / Middle / High
▼▲	Select Item
◀▶	Change value
[Menu]	Back

Figure 24: OSD - FOCUS

Focus Mode

Auto	The camera determines the focus position by itself and will adjust to the contents of the filmed object.
Manual	The user is able to set a fixed focus position manually. This can be useful when the contents of the filmed object are not clear towards the background and the autofocus has difficulty finding the correct focusing.
One-push	The camera will focus once and will keep the focus in that position until another focus command is sent.

AF-Zone

This setting defines the area where the autofocus is aimed at.

Front Focus:	Focus on the front object first, but this is not absolute prefocus.
Back Focus:	Focus back first, but this is not absolute focus
Meeting:	For general meeting scenarios
Education Tracking:	*This is for education tracking, is the teacher on the platform to move back and forth, focus will only be to fine-tune.
Moving Objects:	For scenes where characters move frequently.
Center Focus:	Focus first on the middle object, but this focus is not absolute.



*Note that this is about focussing on the Teacher. This mode will not literally track anyone!

AF-sensitivity

Sets the level of speed with which the autofocus responds. This can be useful if you have people walking through the picture. If the setting is 'High', the camera will respond immediately. If the setting is 'Low' or 'Medium', the camera will not react to sudden and short changes in the picture.



Note that in some cases the autofocus will have some difficulties to focus. We strongly recommend to focus manually to avoid autofocus issues. See also the Troubleshooting/ Image in this manual.

3.5 NOISE REDUCTION

NOISE REDUCTION	
▶	NR-2D 1 ~ 7 / Auto / OFF
	NR-3D 1 ~ 8 / Auto / OFF
	Dynamic Hot Pixel 1 ~ 5 / OFF
▼▲	Select Item
◀▶	Change value
[Menu]	Back

Figure 25: OSD - NOISE REDUCTION

Noise reduction can be used to soften the image when noise is present due to poor lighting conditions. The higher the amount of noise reduction, the softer the image will get, ultimately resulting in losing details.

Be careful when adjusting the noise reduction, as it can take away the natural 'crispness' of the image. You will lose the natural 'crispness' of the image, if you set the dynamic contrast and gain too high (this will cause more noise). Better practice is to add light to the filmed object.

The settings are as follows:

NR-2D	Used for still-standing objects.
NR-3D	Used for moving objects.
Dynamic Hot Pixel	A dynamic hot pixel is a defective pixel which look much brighter than they should and will sometimes become visible due to long exposure shots of the camera at a higher rate of light sensitivity. This is often visible as sparkles in the picture. The Dynamic Hot Pixels mode corrects the pixel so that the pixel will appear as normal on the filmed picture.

3.6 STYLE

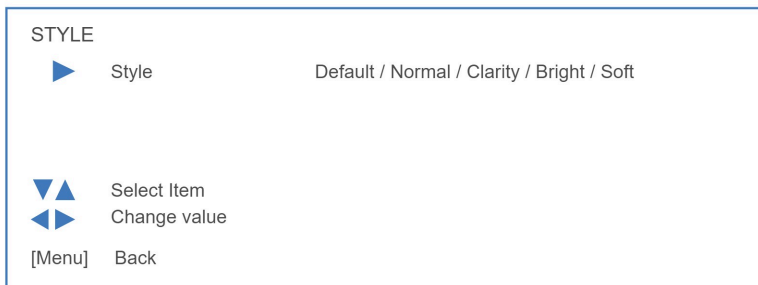

Here, you can choose the style you want, such as **Default** (standard setting), **Normal** (makes the picture more 'natural'), **Clarity** (makes the picture more clear), **Bright** (brightens the picture) and **Soft** (softens the picture).

Figure 26: OSD - STYLE

4. PTZ

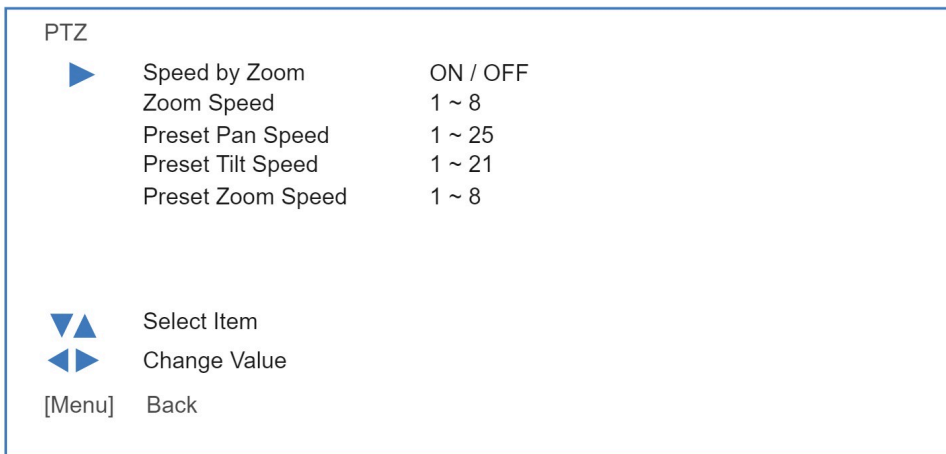

In this window, you can define various P/T/Z settings for your camera. These are:

Figure 27: OSD - PTZ

Speed by zoom	This mode affects PTZ speed when the camera is zoomed in to its max. If you move the stick of your controller when this mode is disabled, it will move too fast to control it. Enabling reduces this speed in relation to the current zoom factor.
Zoom Speed	You can set the speed to which the camera will zoom in to the image. The higher the number, the faster the camera will zoom in. This works only when the remote controller is used to control the camera.
Preset Pan, Tilt and Zoom Speed	This mode affects the speed to which the camera is switching from one preset to another when you use your (remote) controller. The higher the number, the faster it will switch.

5. NETWORK SETTINGS

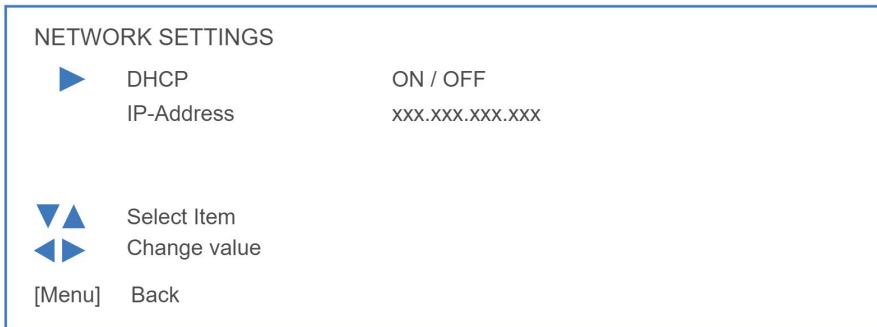

Figure 28: OSD - NETWORK SETTINGS

In this section the IP-settings for the ethernet adapter can be made. You can set the DHCP to ON or OFF, or you can set the IP Address.

6. VERSION

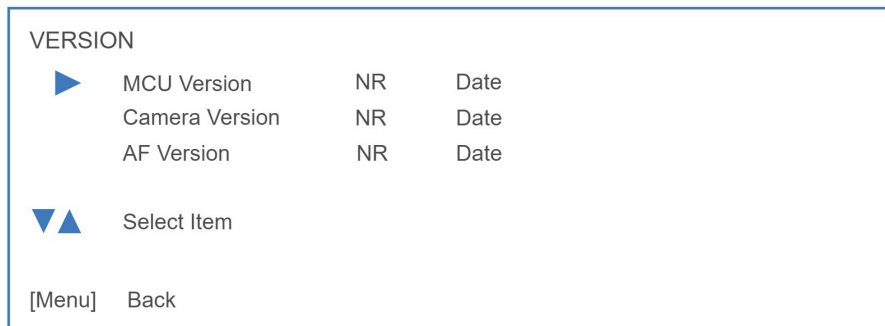

Figure 29: OSD - VERSION

No changes can be made. This is to view the MCU, Camera and AF Version you have.

7. RESTORE DEFAULT

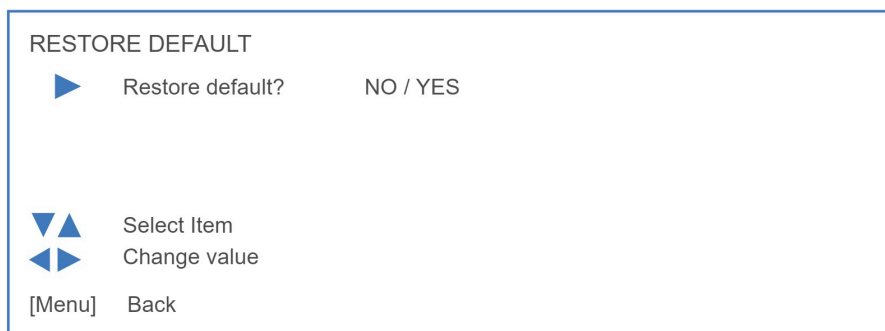



Figure 30: OSD - RESTORE DEFAULT

Here you can restore all the settings to the factory default settings by selecting YES.

WebGUI

You can access the camera remotely through a WebGUI where you can change network and system settings.

Login



User Name:

Password:

Figure 31: WebGUI > Login



Execute the following steps to log in to the WebGUI:

1. Open your web browser.
2. Enter the default IP address "192.168.5.163" in the URL box. The "Login" screen appears.
3. Enter "admin" for both the "User Name" and "Password" and click **LOGIN** to continue.



If **DHCP** is enabled and no **DHCP** server is available, the camera will automatically appoint an IPv4 link-local address between **169.254.0.0** and **169.254.255.255**. The IP address is shown on the screen at start-up.

After a successful login, the WebGUI is displayed. Here, you can select various tabs that are described below.

NETWORK

Port Settings

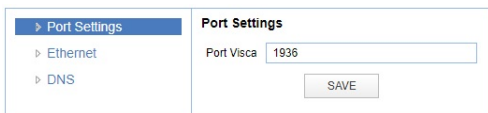

Port Settings

Port Visca:

Figure 32: WebGUI > NETWORK > Port Settings

You can define the VISCA port for control of the camera by using the VISCA protocol.



Make sure that this setting doesn't interfere with other uses and services on the same network.



Click **SAVE** to apply your settings. A small confirmation dialogue appears in the bottom right corner.

NETWORK - Ethernet

In this section, you can specify the IP settings for the Ethernet adapter.

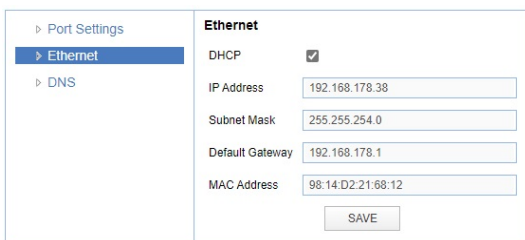

Ethernet

DHCP:

IP Address:

Subnet Mask:

Default Gateway:

MAC Address:

Figure 33: WebGUI > NETWORK > Ethernet



Execute the following steps to save your settings:

1. Click **SAVE**. A small confirmation dialogue appears in the bottom right corner.
2. Reboot the camera.

NETWORK - DNS

Here, you can specify the **Preferred** and **Alternative DNS Server**.

Figure 34: WebGUI > NETWORK > DNS



Click **SAVE** to apply your settings. A small confirmation dialogue appears in the bottom right corner.

SYSTEM

User

Figure 35: WebGUI > SYSTEM > User

You can define different users with specific permission levels and different username / passwords combinations. There are 2 levels of users: **administrators** with access to all features, and **user-1** and **user-2** with access to the preview and PTZ controls. Click **SAVE** to apply your settings.

It is also possible to fill in automatically your user name and password using your browser. To do this save your username and password in your browser, enable the HTTP Basic Authentication and click **SAVE**.



Note that, if you enable the HTTP Basic Authentication (and save it), you **cannot** log out in the traditional way! To log out from the WebGUI, disable this option and **refresh** your browser. See the picture above.

Update

Figure 36: WebGUI > SYSTEM > Update

By default, this screen shows a readout of the current firmware versions. The **Update file** provides a firmware upgrade functionality via this screen. When the camera is done uploading and processing the update, it will automatically reboot.



Execute the following steps to perform a firmware upgrade.

1. Click **Choose File** to select the firmware update file.
2. Click **UPGRADE** to start the firmware upgrade wizard.
3. Follow the steps in the wizard.
4. Wait until the process finishes and reboots.
5. Refresh your browser and log in again after the reboot.

Default

If necessary, you can perform a factory reset. This restores all default settings.



Figure 37: WebGUI > SYSTEM > Default



Use the **Default** button to perform a factory reset. When completed, the camera automatically reboots. The camera will be ready for use again after the boot cycle.

Reboot

If necessary, you can manually perform a camera reboot.

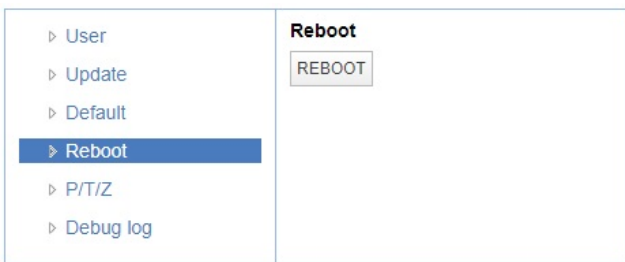

Figure 38: WebGUI > SYSTEM > Reboot



Use the **Reboot** button to reboot the camera. It will be ready for use again after the boot cycle.

P/T/Z

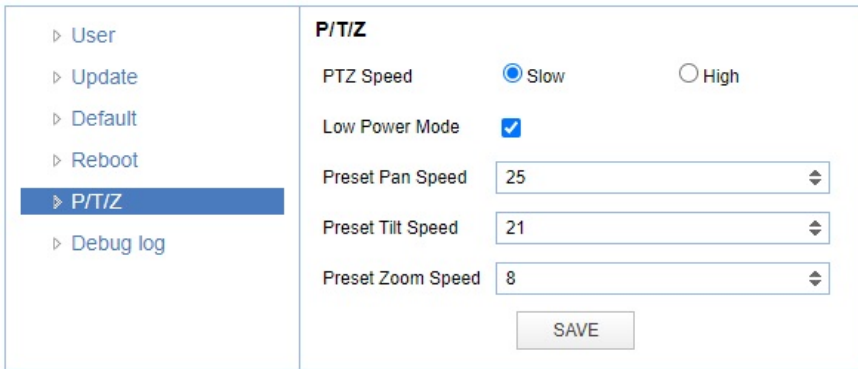

Figure 39: WebGUI > SYSTEM > P/T/Z

In this window, you can define various P/T/Z settings for your camera. See [OSD Menu - PTZ](#). The PTZ speed is a WebGUI **ONLY** feature. This feature determines how fast you can move the camera. See below:

	Slow	High
Panning Speed:	100° per sec.	120° per sec.
Tilting Speed	35° per sec.	70° per sec.



- The camera will make more noise in high mode when it moves.

Debug Log

In this tab you can download a log file with information from the focus of the camera in it.

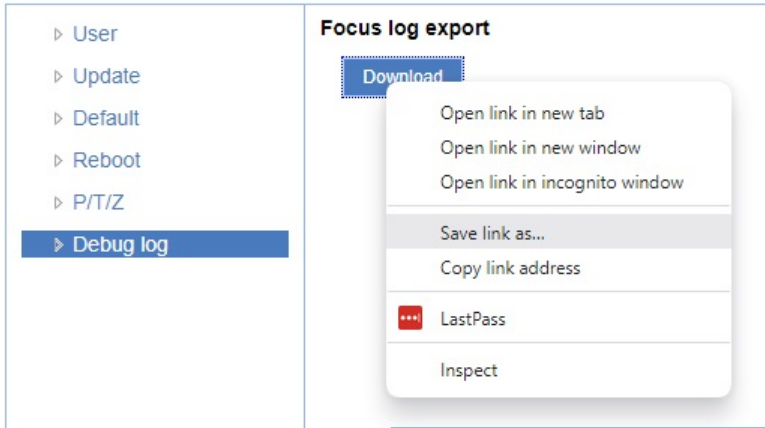

Figure 40: WebGUI > System > Debug Log



Click **RIGHT** and then at "Save link as..." to download the log file.

MAINTENANCE

Camera Maintenance



Take the following actions to maintain the camera:

- If you will not be using the camera for a long time, turn off the power switch and disconnect the AC powercord of the AC adaptor to the outlet.
- Use a soft cloth or tissue to clean the camera cover.
- Please use the soft dry cloth to clean the lens. If the camera is very dirty, clean it with diluted neutral detergent.



Do not use any type of solvents, which may damage the surface.

Usage Precautions



Take the following precautions to ensure good image quality:

- Do not film extreme bright objects for a prolonged period of time, such as sunlight, light sources, etc.
- Do not operate in unstable lighting conditions, otherwise the produced image could be less than optimal.
- Do not operate close to powerful electromagnetic radiation, such as TV or radio transmitters, etc.

TRANSPORT AND STORAGE

The camera must be transported in its original packaging box. Inside the box, it is recommended to wrap the camera in the original plastic bag and to place it in the protective foam.

Specific guidelines apply to the environmental temperature and humidity when operating and storing the camera.



See 'Operating humidity' and 'Storage temperature' in the provided Datasheet for the applicable values.

DISPOSAL AND RECYCLING

In general, the term 'E-Waste' applies to items of all types of electrical and electronic equipment and its parts that have been discarded by the owner as waste without the intention of re-use.

Avonic outsources the disposal and recycling of its E-Waste camera materials to the **Stichting Open**.



See <https://stichting-open.org/> for more information about the disposal and recycling.

TROUBLESHOOTING

General

-  1. Turn the camera off and on again and check if the problem persists.
- 2. If it does, restore to the factory default.

Power Issues

-  If the camera does NOT perform a self-test and / or if the power LED is OFF:
 1. Check the net power.
 2. Check the power supply.
 3. Check the physical power button on the back of the camera.

Image

No image

- 
 1. Check the power of the camera and monitor.
 2. Check the quality and length of the video cable.
 3. Check if the video specifications of monitor match the specifications of the camera.
 4. Check if the Iris under **Exposure settings** is set to 'closed'.

Abnormal image

- 
 1. Check the quality and length of the video cable.
 2. Check the cable connections.
 3. Check if the Iris under **Exposure settings** is set to 'closed'.

Dithering or flickering image

- 
 1. Check the camera fixation and nearby vibration sources.
 2. Check the **Anti-flickering** setting in the OSD.
 3. Check the **Noise Reduction** settings in the OSD.



Color issues

-  Check the OSD settings for exposure, white balance, color temp, Red and Bluetuning.



When experiencing image problems, you may also check [Appendix D - CMOS Image Sensor Characteristics](#).

Autofocus Issues

- 
 - Check the autofocus (position, speed etc.) before streaming
 - Check Video/Camera Settings in de WebGUI or the OSD menu (for example: if the image is too bright, too dark, or too noisy, the camera will have difficulties to focus)
-  Check environmental conditions and the subject of focussing. The camera will have difficulties to focus in the following situations:
 - Light: Strong light, low light/dark areas and backlight conditions
 - Moving subjects
 - Small objects before a plain or solid background
 - Blurry or unsharp subjects: filming through wet glass or dirty objects
 - Distance: filming two or more different subjects, some near and some far away

- Position in the image: subject positioned in the corners of the picture
- Faces: partly hidden faces, sideways filmed faces, diagonal or up side down
- When the camera itself moves, or when the iris is narrowed down



When you experience one or more of the above mentioned problems check also our [Appendix - CMOS characteristics](#)

Control

No self-test (PTZ cameras only) and no power LED



1. Check the net power
2. Check the power supply

Remote Controller does not work



1. Check the power of the controller.
2. Check the RS-232 or RS-485 cable quality, length, polarity and network architecture.
3. Check the serial communication settings on the camera and controller.
4. Check the VISCA / PELCO address settings on the camera and controller.
5. Check the IP network settings on the camera and controller.

WebGUI

Cannot enter WebGUI



1. Check the network cable.
2. Check if the computer is connected to the same subnet as the camera.
3. Use an **incognito** window in your browser, sometimes cache issues arise when using multiple cameras that have the same default IP address
4. Reset the factory default IP settings by pressing [*] [#] **[Manual]** and **Reboot**.

Firmware update failed



1. Check firmware file integrity, download it again.
2. Make sure you are trying to flash the UVC file for the correct color camera (ARM is generic, UVC is color-dependent).

APPENDIX A - VISCA SETTINGS AND COMMAND LIST

VISCA is a professional camera control protocol used with PTZ cameras. It works by sending commands to the camera either over a serial or over an IP connection, in return the camera sends ACK acknowledgment and COM completion answers to let the sender know the commands have been received and completed. The [list](#) below describes the commands, ranges and camera answers.

The VISCA Settings and Command list is available as an appendix in this manual and as an separate document that you can download on the [product website](#).

VISCA over Serial Connection

VISCA is based on RS232 Serial communications at 9600 bit/s, 8N1, no flow control. VISCA uses a serial repeater network configuration to communicate between the controller (device #0) and up to 7 peripherals (#1 through #7). The daisy chain cable configuration means that a message walks the chain until it reaches the target device identified in the data packet. Responses then walk the rest of the way down the chain and back up again to reach the sender. Some packets are broadcast to all devices.

A command data packet consists of:

- Address byte (1) message header
- Information bytes (1..14)
- Terminating byte (1) 0xFF



You can use **Hercules SETUP Utility** application and a serial connection to make this work.

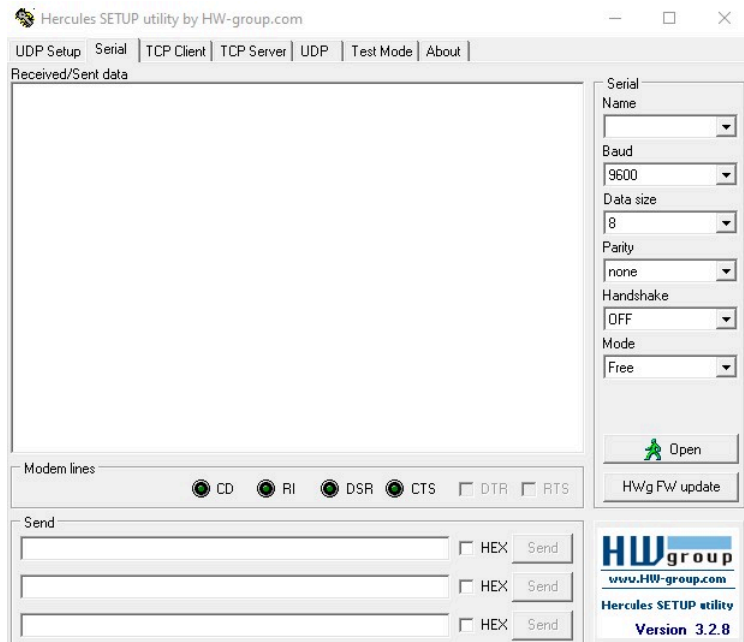

VISCA over IP

Avonic IP cameras are implemented with a TCP and an UDP server. The TCP as well as the UDP port are by default set to port [1259](#).



The default VISCA address setting is **always 1** when using VISCA over IP. As all cameras are uniquely identified by their IP address, all VISCA addresses are set to 1, the serial addressing plays no part. For VISCA over IP, every command starts with **81 xx xx xx**.



To control the camera, you need an TCP or UDP supported application, like **Hercules SETUP utility** or **Packet Sender** for example. Follow the instructions below:

1. Open the TCP/ UDP supported application.
2. Fill in the camera's IP Address, TCP/UDP port number and connect the application to your camera.
Once the connection between client and server is set up, the client will be able to send PTZ commands to the server. The server then parses and executes the PTZ command.
3. Fill in the command to be sent to the camera. The camera will send you the return commands.
4. If you see the returned commands (in exception with UDP), the camera has executed the command. You can check this in the WebGUI of the camera.



Default settings:

- TCP port 1259
- UDP port 1259 (same port as TCP; is correct)
- VISCA address 1

The pictures below are showing an example of a VISCA command (Focus near) with their return commands. The green RX commands in the picture "Receive message" is the ACK command (to let the sender know that the command is received and executed) and the COM command (to confirm that the command has been successfully executed and completed). You can find these commands in the [Camera Return Command list](#) and the [Inquiry Command list](#).



Note that the pictures below are ONLY an example to show you how a TCP supported application works. The pictures could be different from the application you are using!

Net

Protocol
 TCP UDP

IP Address

Port

PTZ Manual

8x 01 04 08 03 FF > 81 01 04 08 03 FF

VISCA IP address and port

VISCA command example

Receive message

TX: 81 01 04 08 03 FF (11:33:44.785)

RX: 90 41 FF (11:33:44.791)

RX: 90 51 FF (11:33:44.844)

VISCA over IP using the full Sony VISCA protocol

All Avonic cameras are capable of being controlled using the UDP Sony version of VISCA consisting of long VISCA commands, including headers and message counters. The advantage of using this version of VISCA is the fact that the camera responds with the same header **counter** as was used in the command. This makes it possible to match each response to each command sent. This is especially helpful when programming automated camera control systems.



For the following example Hercules SETUP utility is used to recall preset 1 using VISCA. Follow the instructions below:

1. Set the local port and camera port. Both must be set to **52381**. Any other port won't work!

The camera will send its answers back to the port that was used to send the command (port 52381).



Make sure that you have your **sent and receive** window set to display HEX data.

In the example below the camera is switched between:

- Preset 1: VISCA command 81 01 01 3F 02 01 FF and
- Preset 2: VISCA command 81 01 01 3F 02 02 FF



1. Type the command in the **Send** box. The command consists of the **(camera) address**, marked in blue and 7 bytes marked in red. This means that the complete VISCA command looks like this:
 - Preset 1: VISCA command 010000070000000181**0101F0201FF**
 - Preset 2: VISCA command 010000070000000581**013F0202FF**

The Visca over IP header consists of the 3rd and 4th bytes of the complete header. They indicate length of the payload (VISCA command). At this point, the value can vary depending on what VISCA command is sent. Using the example of **Preset Recall 1** from above:

- 010000070000000181**01013F0201FF** the 4th byte is '7' meaning the payload of the VISCA command is 7 bytes. Another point in the header is the message counter possibility on the 8th byte, in this instance it's '1'. On the second command where **Preset 2** was recalled, the message counter was set to '5'.



1. Click on **Send**. If you have done this correct, you should get the same as on the picture below:

The screenshot shows the Hercules SETUP utility interface. The 'UDP data' section displays received data in hexadecimal: `{FF}{01}{11}{00}{03}{00}{00}{00}{01}{90}{41}{FF}{01}{11}{00}{03}{00}{00}{00}{01}{90}{51}{FF}{01}{11}{00}{03}{00}{00}{00}{05}{90}{41}{FF}{01}{11}{00}{03}{00}{00}{00}{05}{90}{51}`. The 'Sent data' section shows: `{01}{00}{00}{07}{00}{00}{00}{01}{81}{01}{04}{3F}{02}{01}{FF}` and `{01}{00}{00}{07}{00}{00}{00}{05}{81}{01}{04}{3F}{02}{02}{FF}`. The 'Send' section contains three commands: `01000007000000018101043F0201FF`, `01000007000000058101043F0202FF`, and `01000005000001581010604FF`, each with a checked 'HEX' box and a 'Send' button. The right sidebar shows UDP settings: Module IP (172.26.40.169), Port (52381), Local port (52381), and a 'Close' button. Server settings include 'Server echo', 'Redirect to TCP Server', and 'Redirect to TCP Client'. UDP broadcast settings show 'File name: No file' and 'Send' and 'Load file' buttons. The HW group logo and version 3.2.8 are visible in the bottom right.

Camera Return Commands

All parameter values are in HEX.

- x = Camera Address
- y = Socket Number
- z = Camera Address + 8



This is one list for all Avonic PTZ Cameras (CM40 series and CM70 series). Some features are CM70 series ONLY and will not work with a CM40 series camera.

Return/complete Command			
Command	Function	Command Packet	Comments
ACK/Completion Messages	ACK	90 4y FF (y: Socket No.)	Return when the command is accepted.
	Completion	90 5y FF (y: Socket No.)	Return when the command has been executed.

Error Command			
Command	Function	Command Packet	Comments
Error Messages	Syntax Error	90 60 02 FF	Returned when the command format is different or when a command with illegal command parameters is accepted.
	Command Buffer Full	90 60 03 FF	Indicates that two sockets are already being used (executing two commands) and the command could not be accepted when received.
	Command Canceled	90 6y 04 FF (y: Socket No.)	Returned when a command which is being executed in a socket specified by the cancel command is canceled. The completion message for the command is not returned.
	No Socket	90 6y 05 FF (y: Socket No.)	Returned when no command is executed in a socket specified by the cancel command, or when an invalid socket number is specified.
	Command Not Executable	90 6y 41 FF (y: Execution command Socket No. Inquiry command: 0)	Returned when a command cannot be executed due to current conditions. For example, when commands controlling the focus manually are received during auto-focus.

Camera Control Commands

All parameter values are in HEX

- x = Camera Address
- y = Socket Number
- z = Camera Address + 8

Camera Control Commands			
Command	Function	Command Packet	Comments
Address Set	Broadcast	88 30 01 FF	Address setting
CAM_Power	On	8x 01 04 00 02 FF	Power ON
	Off	8x 01 04 00 03 FF	Power OFF
	Reboot	8x 0A 01 06 01 FF	Reboot
CAM_Zoom	Stop	8x 01 04 07 00 FF	
	Tele (Standard speed)	8x 01 04 07 02 FF	
	Wide (Standard speed)	8x 01 04 07 03 FF	
	Tele (Variable speed)	8x 01 04 07 2p FF	p = 0(low speed) -F(high speed)
	Wide (Variable speed)	8x 01 04 07 3p FF	
	Direct	8x 01 04 47 0p 0q 0r 0s FF	pqrs(0-F): Zoom Position
	Zoom Wide ~ Tele	00 00 00 00 ~ 04 00 00 00 (PQRS)	
CAM_Focus	Stop	8x 01 04 08 00 FF	
	Far (Standard speed)	8x 01 04 08 02 FF	
	Near (Standard speed)	8x 01 04 08 03 FF	
	Far (Variable speed)	8x 01 04 08 2p FF	p = 0(low) - F(high)
	Near (Variable speed)	8x 01 04 08 3p FF	
	Direct Focus Position	8x 01 04 48 0p 0q 0r 0s FF	min p = 0, q = 0, r = 0, s = 0 max p = 0, q = 6, r = E, s = A
	Auto Focus	8x 01 04 38 02 FF	AF On
	Manual Focus	8x 01 04 38 03 FF	AF Off
	Auto/Manual	8x 01 04 38 10 FF	AF Toggle On/Off
	OnePush mode	8x 01 04 38 04 FF	
	OnePush trigger	8x 01 04 18 01 FF	
Focus Near ~ Far	Variable ~ 00 00 00 00 (PQRS)	pqrs: Focus Position	
CAM_WB	Auto	8x 01 04 35 00 FF	Normal Auto
	Indoor mode	8x 01 04 35 01 FF	Indoor mode
	Outdoor mode	8x 01 04 35 02 FF	Outdoor mode
	OnePush mode	8x 01 04 35 03 FF	One Push WB mode
	OnePush trigger	8x 01 04 10 05 FF	One Push WB Trigger
	Manual	8x 01 04 35 05 FF	Manual Control mode

Camera Control Commands			
Command	Function	Command Packet	Comments
CAM_Bgain	Reset	8x 01 04 04 00 FF	Manual Control of BGain
	Up	8x 01 04 04 02 FF	
	Down	8x 01 04 04 03 FF	
	Direct	8x 01 04 44 00 00 0p 0q FF	pq: B Gain
CAM_Rgain	Reset	8x 01 04 03 00 FF	Manual Control of RGain
	Up	8x 01 04 03 02 FF	
	Down	8x 01 04 03 03 FF	
	Direct	8x 01 04 43 00 00 0p 0q FF	pq: R Gain
CAM_AE	Full Auto	8x 01 04 39 00 FF	Automatic Exposure mode
	Manual	8x 01 04 39 03 FF	Manual Control mode
	Shutter priority	8x 01 04 39 0A FF	Shutter Priority Automatic Exposure mode
	Iris priority	8x 01 04 39 0B FF	Iris Priority Automatic Exposure mode
	Bright	8x 01 04 39 0D FF	Bright Mode (Manual control)
CAM_Iris	Reset	8x 01 04 0B 00 FF	Iris Setting (CAM_AE is set to Manual)
	Up	8x 01 04 0B 02 FF	
	Down	8x 01 04 0B 03 FF	
	Direct Iris Position	8x 01 04 4B 00 00 0p 0q FF	(Manual and Iris Priority) min p = 0 q = 0 max p = 0, q = C
CAM_Shutter	Direct	8x 01 04 4A 00 00 0p 0q FF	min p = 0 q = 0 max p = 1 q = 0
CAM_Gain	Reset	8x 01 04 0C 00 FF	Gain Setting
	Direct	8x 01 04 0C 00 00 0p 0q FF	pq: Gain Position 0 ~ 20 (0 = 00 HEX) Manual exposure
	Gain Limit	8x 01 04 2C 0p FF	p: Gain Position 0 ~ 15 (0 = 00 HEX) Auto exposure
CAM_Bright (only works with exposure mode Bright enabled)	Reset	8x 01 04 0D 00 FF	Bright Setting
	Up	8x 01 04 0D 02 FF	
	Down	8x 01 04 0D 03 FF	
	Direct	8x 01 04 0D 00 00 0p 0q FF	pq: Bright Position (0 ~ 23 max p = 1 and q = 7)
CAM_ExpComp(EV and EV Level)	On	8x 01 04 3E 02 FF	Exposure Compensation On/Off
	Off	8x 01 04 3E 03 FF	
	Reset	8x 01 04 0E 00 FF	Exposure Compensation Amount Setting
	Up	8x 01 04 0E 02 FF	
	Down	8x 01 04 0E 03 FF	
	Direct	8x 01 04 4E 00 00 0p 0q FF	

Camera Control Commands			
Command	Function	Command Packet	Comments
CAM_BackLight	On	8x01 04 33 02 FF	Back Light Compensation On/Off
	Off	8x01 04 33 03 FF	
CAM_NR(2D)Level	-	8x01 04 53 0p FF	p: NR Setting (0: Off, level 1 to 7, 8 = AUTO)
CAM_NR(3D)Level	-	8x01 04 54 0p FF	p: NR Setting (0: Off, level 1 to 8)
CAM_Flicker	-	8x01 04 23 0p FF	p: Flicker Settings (0: Off, 1: 50Hz, 2: 60Hz)
CAM_DHotPixel	-	8x01 04 56 0p FF	p: Dynamic Hot Pixel Setting (0: Off, level 1 to 5)
CAM_Aperture (sharpness)	Reset	8x01 04 02 00 FF	Aperture Control
	Up	8x01 04 02 02 FF	
	Down	8x01 04 02 03 FF	
	Direct	8x01 04 42 00 00 0p 0q FF	pq: Aperture Gain
CAM_PictureEffect	Off	8x01 04 63 00 FF	Picture Effect Setting
	B&W	8x01 04 63 04 FF	
CAM_Memory(preset)	Reset	8x01 04 3F 00 pp FF	pp: Memory Number (=0 to 127)
	Set	8x01 04 3F 01 pp FF	
	Recall	8x01 04 3F 02 pp FF	
CAM_LR_Reverse	On	8x01 04 61 02 FF	Image Flip Horizontal On/Off
	Off	8x01 04 61 03 FF	
CAM_PictureFlip	On	8x01 04 66 02 FF	Image Flip Vertical On/Off
	Off	8x01 04 66 03 FF	
Freeze (CM70 series ONLY)	Freeze ON	8x04 04 62 02 FF	Freeze ON immediately
	Freeze OFF	8x04 04 62 03 FF	Freeze OFF immediately
	Preset Freeze ON	8x04 04 62 22 FF	Freeze ON when running preset
	Preset Freeze OFF	8x04 04 62 23 FF	Freeze OFF when running preset
SYS_Menu	Off	8x01 06 06 03 FF	Turns the OSD menu On/Off
	On	8x01 06 06 02 FF	
CAM_ColorGain	Direct	8x01 04 49 00 00 00 0P FF	p: Color Gain setting 0h (60%) to Eh (200%)

Camera Control Commands			
Command	Function	Command Packet	Comments
Pan_tiltDrive	Up	8x01 06 01 VV WW 03 01 FF	VV: Pan speed 0x01 (low speed) to 0x18 (high speed) WW: Tilt speed 0x01 (low speed) to 0x14 (high speed) YYYY: Pan Position ZZZZ: Tilt Position
	Down	8x01 06 01 VV WW 03 02 FF	
	Left	8x01 06 01 VV WW 01 03 FF	
	Right	8x01 06 01 VV WW 02 03 FF	
	Upleft	8x01 06 01 VV WW 01 01 FF	
	Upright	8x01 06 01 VV WW 02 01 FF	
	DownLeft	8x01 06 01 VV WW 01 02 FF	
	DownRight	8x01 06 01 VV WW 02 02 FF	
	Stop	8x01 06 01 VV WW 03 03 FF	
	AbsolutePosition	8x01 06 02 VV WW 0Y 0Y 0Y 0Y 0Z 0Z 0Z 0Z FF	
	RelativePosition	8x01 06 03 VV WW 0Y 0Y 0Y 0Y 0Z 0Z 0Z 0Z FF	
	Pan range: -170° ~ +170°	0F 06 07 00 ~ 50 00 09 09 (YYYY)	
	Tilt range: -30° ~ +90°	0F 0E 04 05 ~ 00 05 01 00 (ZZZZ)	
	Home	8x01 06 04 FF	
Reset	8x01 06 05 FF		
Pan_tiltLimitSet	LimitSet	8x01 06 07 00 0W 0Y 0Y 0Y 0Y 0Z 0Z 0Z 0Z FF	W: 1 UpRight 0: Down-Left YYYY: Pan Limit Position ZZZZ: Tilt Position
	LimitClear	8x01 06 07 01 0W 07 0F 0F 0F 0F 0F 0F 0F FF	
CAM_AFsensitivity	High	8x01 04 58 01 FF	AF Sensitivity High/Normal/Low
	Normal	8x01 04 58 02 FF	
	Low	8x01 04 58 03 FF	
CAM_SettingReset	Reset	8x01 04 A0 10 FF	Reset Factory Setting
CAM_Brightness	Direct	8x01 04 A1 00 00 0p 0q FF	pq: Brightness Position
CAM_Contrast	Direct	8x01 04 A2 00 00 0p 0q FF	pq: Contrast Position
CAM_Flip	Off	8x01 04 A4 00 FF	Single Command For Video Flip
	Flip-H	8x01 04 A4 01 FF	
	Flip-V	8x01 04 A4 02 FF	
	Flip-HV	8x01 04 A4 03 FF	
CAM_Autoflip	Autoflip ON	8x01 02 70 02 FF	Autoflip ON
	Autoflip OFF	8x01 02 70 03 FF	Autoflip OFF
CAM_SettingSave	Save	8x01 04 A5 10 FF	Save Current Setting
CAM_Iridix	Direct	8x01 04 A7 00 00 0p 0q FF	pq: Iridix Position
CAM_AWBSensitivity	High	8x01 04 A9 00 FF	High
	Normal	8x01 04 A9 01 FF	Normal
	Low	8x01 04 A9 02 FF	Low

Camera Control Commands			
Command	Function	Command Packet	Comments
CAM_AFZone	Front Focus	8x 01 04 AA 00 FF	AF Zone select
	Back Focus	8x 01 04 AA 01 FF	
	Meeting	8x 01 04 AA 02 FF	
	Education Tracking	8x 01 04 AA 03 FF	
	Moving Objects	8x 01 04 AA 04 FF	
	Center Focus	8x 01 04 AA 05 FF	
CAM_ColorHue	Direct	8x 01 04 4F 00 00 00 0p FF	p: Color Hue setting 0h (-14 degrees) to Eh (+14 degrees)
Pan-tilt_MaxSpeed	High SpeedPan/Tilt ON	8x 0A 01 31 03 FF	High Speed PTON
	High SpeedPan/Tilt OFF	8x 0A 01 31 02 FF	High Speed PTOFF
ARM/MCU_Version	Inquiry ARM/MCU Version	8x 09 0A 01 03 FF	Returned version in HEX, for example: 02 05 00 (version 2.5.0)
CAM/UVC_Version	Inquiry Cam/UVC version	8x 09 00 02 FF	Returned version in HEX, for example: 02 05 09 (version 2.5.9)
CAM_TallyLight(Cm7x only with license active)	Red	8x 01 7E 01 0A 00 02 03 FF	Tally Light RedON
	Green	8x 01 7E 01 0A 00 03 02 FF	Tally Light GreenON
	Off	8x 01 7E 01 0A 00 03 03 FF	Tally Light OFF
Preset_H_Speed	Horizontal (Pan) speed between presets	81 01 03 01 qq FF	qq = speed setting 1 ~ 25 (1 = 00 HEX, 25 = 18 HEX)
Preset_V_Speed	Vertical (Tilt) speed between presets	81 01 03 02 qq FF	qq = speed setting 1 ~ 21 (1 = 00 HEX, 21 = 14 HEX)
Preset_Z_Speed	Zoom speed between presets	81 01 03 03 qq FF	qq = speed setting 1 ~ 8 (1 = 00 HEX, 8 = 07 HEX)
Blue_Tuning (autowhitebalance active)	more or less blue while maintaining auto white balance active	81 0A 01 13 pp FF	pp = setting -10 ~ +10(00~14 HEX)
Red_Tuning (autowhitebalance active)	more or less red while maintaining auto white balance active	81 0A 01 12 pp FF	pp = setting -10 ~ +10(00~14 HEX)

Camera Control Commands			
Command	Function	Command Packet	Comments
VideoSystem_Set (CM40 series: It is possible to set the video format, but since the video format is dictated by the computer the camera is connected with, the picture will NOT change to that format.)		8x01 06 35 00 pp FF	pp: Video Format
			00: 1080p60
			01: 1080p50
			02: 1080i60
			03: 1080i50
			04: 720p60
			05: 720p50
			06: 1080p30
			07: 1080p25
			08: 720p30
			09: 720p25
			0A: 1080p59.94
			0B: 1080i59.94
			0C: 720p59.94
0D: 1080p29.97			
0E: 720p29.97			

Inquiry Commands

all parameter values are in hex

- x = camera address
- y = socket number
- z = camera address + 8

Inquiry Commands			
Command	Function	Command Packet	Comments
CAM_ZoomPosInq	8x 09 04 47 FF	90 50 0p 0q 0r 0s FF	pqrs: Zoom Position
CAM_FocusAFModelInq	8x 09 04 38 FF	90 50 02 FF	Auto Focus
		90 50 03 FF	Manual Focus
		90 50 04 FF	OnePush Focus
CAM_FocusPosInq	8x 09 04 48 FF	90 50 0p 0q 0r 0s FF	pqrs: Focus Position
CAM_WBModelInq	8x 09 04 35 FF	90 50 00 FF	Auto
		90 50 01 FF	Indoor mode
		90 50 02 FF	Outdoor mode
		90 50 03 FF	OnePush mode
		90 50 05 FF	Manual
CAM_RGainInq	8x 09 04 43 FF	90 50 00 00 0p 0q FF	pq: R Gain
CAM_BGainInq	8x 09 04 44 FF	90 50 00 00 0p 0q FF	pq: B Gain
CAM_GainInq (CM70 series ONLY)	8x 09 04 0C FF	90 50 00 FF	Manual Exposure Direct Gain
CAM_AEModelInq	8x 09 04 39 FF	90 50 00 FF	Full Auto
		90 50 03 FF	Manual
		90 50 0A FF	Shutter priority
		90 50 0B FF	Iris priority
		90 50 0D FF	Bright
CAM_ShutterPosInq	8x 09 04 4A FF	90 50 00 00 0p 0q FF	pq: Shutter Position
CAM_IrisPosInq	8x 09 04 4B FF	90 50 00 00 0p 0q FF	pq: Iris Position
CAM_BrightPosInq	8x 09 04 4D FF	90 50 00 00 0p 0q FF	pq: Bright Position
CAM_ExpComp-ModelInq	8x 09 04 3E FF	90 50 02 FF	On
		90 50 03 FF	Off
CAM_ExpCompPosInq	8x 09 04 4E FF	90 50 00 00 0p 0q FF	pq: ExpComp Position
CAM_Backlight-ModelInq	8x 09 04 33 FF	90 50 02 FF	On
		90 50 03 FF	Off
CAM_Noise2DLevel	8x 09 04 53 FF	90 50 0p FF	Noise Reduction (2D) p: 0 to 7, 8 = AUTO
CAM_Noise3DLevel	8x 09 04 54 FF	90 50 0p FF	Noise Reduction (3D) p: 0 to 8
CAM_FlickerModelInq	8x 09 04 55 FF	90 50 0p FF	p: Flicker Settings(0: OFF, 1: 50Hz, 2: 60Hz)

Inquiry Commands			
Command	Function	Command Packet	Comments
CAM_Aperture-Modelnq (Sharpness)	8x 09 04 05 FF	90 50 02 FF	Auto Sharpness
		90 50 03 FF	Manual Sharpness
CAM_ApertureInq(Sharpness)	8x 09 04 42 FF	90 50 00 00 0p 0q FF	pq: Aperture Gain
CAM_PictureEffectModelnq	8x 09 04 63 FF	90 50 00 FF	Color
		90 50 04 FF	B&W

Inquiry Commands			
Command	Function	Command Packet	Comments
CAM_MemoryInq	8x 09 04 3F FF	90 50 0p FF	p: Memory (Preset) number last operated.
SYS_MenuModelnq	8x 09 06 06 FF	90 50 02 FF	On
		90 50 03 FF	Off
CAM_LR_ReverseInq	8x 09 04 61 FF	90 50 02 FF	On
		90 50 03 FF	Off
CAM_PictureFlipInq	8x 09 04 66 FF	90 50 02 FF	On
		90 50 03 FF	Off
CAM_ColorGainInq	8x 09 04 49 FF	90 50 00 00 00 0p FF	p: Color Gain setting 0h (60%) to Eh (200%)
CAM_BTuningInq	81 09 0A 01 13 FF	90 50 pp FF	pp = setting -10 ~ +10 (00~14 HEX)
CAM_RTuningInq	81 09 0A 01 12 FF	90 50 pp FF	pp = setting -10 ~ +10 (00~14 HEX)
VideoSystemInq (CM40 series: It is possible to set the video format, but since the video format is dictated by the computer the camera is connected with, the picture will not change to that format.)	8x 09 06 23 FF	90 50 00 FF	1920x1080p60
		90 50 01 FF	1920x1080p50
		90 50 02 FF	1920x1080i60
		90 50 03 FF	1920x1080i50
		90 50 04 FF	1280x720p60
		90 50 05 FF	1280x720p50
		90 50 06 FF	1920x1080p30
		90 50 07 FF	1920x1080p25
		90 50 08 FF	1280x720p30
		90 50 09 FF	1280x720p25
		90 50 0A FF	1920x1080p59.94
		90 50 0B FF	1920x1080i59.94
		90 50 0C FF	1280x720p59.94
		90 50 0D FF	1920x1080p29.97
90 50 0E FF	1280x720p29.97		
Pan-tiltMaxSpeedInq	8x 09 06 11 FF	90 50 ww zz FF	ww: Pan Max Speed zz: Tilt Max Speed

Inquiry Commands			
Command	Function	Command Packet	Comments
Pan-tiltPosInq	8x 09 06 12 FF	90 50 0w 0w 0w 0w 0z 0z 0z 0z FF	www: Pan Position zzz: Tilt Position
CAM_GainLimitInq	8x 09 04 2C FF	90 50 0q FF	p: Gain Limit
	8x 09 04 2C FF	90 50 07 FF	Auto exposure
CAM_DHotPixelInq	8x 09 04 56 FF	90 50 0q FF	p: Dynamic Hot Pixel Setting (0: Off, level 1 to 6)
CAM_AFSensitivityInq	8x 09 04 58 FF	90 50 01 FF	High
		90 50 02 FF	Normal
		90 50 03 FF	Low
CAM_BrightnessInq	8x 09 04 A1 FF	90 50 00 00 0p 0q FF	pq: Brightness Position
CAM_ContrastInq	8x 09 04 A2 FF	90 50 00 00 0p 0q FF	pq: Contrast Position

Inquiry Commands			
Command	Function	Command Packet	Comments
CAM_FlipInq	8x 09 04 A4 FF	90 50 00 FF	Off
		90 50 01 FF	Flip-H
		90 50 02 FF	Flip-V
		90 50 03 FF	Flip-HV
CAM_IridixInq	8x 09 04 A7 FF	90 50 00 00 0p 0q FF	pq: Iridix Position
CAM_AFZone	8x 09 04 AA FF	90 50 00 FF	Front Focus
		90 50 01 FF	Back Focus
		90 50 02 FF	Meeting
		90 50 03 FF	Education Tracking
		90 50 04 FF	Moving Objects
		90 50 05 FF	Center Focus
CAM_ColorHueInq	8x 09 04 4F FF	90 50 00 00 00 0p FF	p: Color Hue setting 0h (-14 degrees) to Eh (+14 degrees)
CAM_AWBSensitivityInq	81 09 04 A9 FF	90 50 00 FF	High
		90 50 01 FF	Normal
		90 50 02 FF	Low
CAM_ZoomPosInq	8x 09 04 47 FF	90 50 0p 0q 0r 0s FF	pqrs: Zoom Position
CAM_FocusAFModelInq	8x 09 04 38 FF	90 50 02 FF	Auto Focus
		90 50 03 FF	Manual Focus
CAM_FocusPosInq	8x 09 04 48 FF	90 50 0p 0q 0r 0s FF	pqrs: Focus Position

Inquiry Commands			
Command	Function	Command Packet	Comments
CAM_WBModelnq	8x 09 04 35 FF	90 50 00 FF	Auto
		90 50 01 FF	Indoor mode
		90 50 02 FF	Outdoor mode
		90 50 03 FF	OnePush mode
		90 50 05 FF	Manual
CAM_RGainInq	8x 09 04 43 FF	90 50 00 00 0p 0q FF	pq: R Gain
CAM_BGainInq	8x 09 04 44 FF	90 50 00 00 0p 0q FF	pq: B Gain
CAM_AEModelnq	8x 09 04 39 FF	90 50 00 FF	Full Auto
		90 50 03 FF	Manual
		90 50 0A FF	Shutter priority
		90 50 0B FF	Iris priority
		90 50 0D FF	Bright
CAM_ShutterPosInq	8x 09 04 4A FF	90 50 00 00 0p 0q FF	pq: Shutter Position
CAM_IrisPosInq	8x 09 04 4B FF	90 50 00 00 0p 0q FF	pq: Iris Position
CAM_BrightPosInq	8x 09 04 4D FF	90 50 00 00 0p 0q FF	pq: Bright Position
CAM_PowerInq	8x 09 04 00 FF	y0 50 02 FF	On
		y0 50 03 FF Off	Off (Standby)

Appendix A1 - Pelco-D Protocol and command List

Function	Byte1	Byte2	Byte3	Byte4	Byte5	Byte6	Byte7
Up	0xFF	Address	0x00	0x08	Pan Speed	Tilt Speed	SUM
Down	0xFF	Address	0x00	0x10	Pan Speed	Tilt Speed	SUM
Left	0xFF	Address	0x00	0x04	Pan Speed	Tilt Speed	SUM
Right	0xFF	Address	0x00	0x02	Pan Speed	Tilt Speed	SUM
Zoom In	0xFF	Address	0x00	0x20	0x00	0x00	SUM
Zoom Out	0xFF	Address	0x00	0x40	0x00	0x00	SUM
Focus Far	0xFF	Address	0x00	0x80	0x00	0x00	SUM
Focus Near	0xFF	Address	0x01	0x00	0x00	0x00	SUM
Set Preset	0xFF	Address	0x00	0x03	0x00	Preset ID	SUM
Clear Preset	0xFF	Address	0x00	0x05	0x00	Preset ID	SUM
Call Preset	0xFF	Address	0x00	0x07	0x00	Preset ID	SUM
Auto Focus	0xFF	Address	0x00	0x2B	0x00	0x01	SUM
Manual Focus	0xFF	Address	0x00	0x2B	0x00	0x02	SUM
Query Pan Position	0xFF	Address	0x00	0x51	0x00	0x00	SUM
Query Pan Position Response	0xFF	Address	0x00	0x59	Value High Byte	Value Low Byte	SUM
Query Tilt Position	0xFF	Address	0x00	0x53	0x00	0x00	SUM
Query Tilt Position Response	0xFF	Address	0x00	0x5B	Value High Byte	Value Low Byte	SUM
Query Zoom Position	0xFF	Address	0x00	0x55	0x00	0x00	SUM
Query Zoom Position Response	0xFF	Address	0x00	0x5D	Value High Byte	Value Low Byte	SUM

Appendix A2 - Pelco-P Protocol and command List

Function	Byte1	Byte2	Byte3	Byte4	Byte5	Byte6	Byte7	Byte8
Up	0xA0	Address	0x00	0x08	Pan Speed	Tilt Speed	0xAF	XOR
Down	0xA0	Address	0x00	0x10	Pan Speed	Tilt Speed	0xAF	XOR
Left	0xA0	Address	0x00	0x04	Pan Speed	Tilt Speed	0xAF	XOR
Right	0xA0	Address	0x00	0x02	Pan Speed	Tilt Speed	0xAF	XOR
Zoom In	0xA0	Address	0x00	0x20	0x00	0x00	0xAF	XOR
Zoom Out	0xA0	Address	0x00	0x40	0x00	0x00	0xAF	XOR
Focus Far	0xA0	Address	0x00	0x80	0x00	0x00	0xAF	XOR
Focus Near	0xA0	Address	0x01	0x00	0x00	0x00	0xAF	XOR
Set Preset	0xA0	Address	0x00	0x03	0x00	Preset ID	0xAF	XOR
Clear Preset	0xA0	Address	0x00	0x05	0x00	Preset ID	0xAF	XOR
Call Preset	0xA0	Address	0x00	0x07	0x00	Preset ID	0xAF	XOR
Auto Focus	0xA0	Address	0x00	0x2B	0x00	0x01	0xAF	XOR
Manual Focus	0xA0	Address	0x00	0x2B	0x00	0x02	0xAF	XOR
Query Pan Position	0xA0	Address	0x00	0x51	0x00	0x00	0xAF	XOR
Query Pan Position Response	0xA0	Address	0x00	0x59	Value High Byte	Value Low Byte	0xAF	XOR
Query Tilt Position	0xA0	Address	0x00	0x53	0x00	0x00	0xAF	XOR
Query Tilt Position Response	0xA0	Address	0x00	0x5B	Value High Byte	Value Low Byte	0xAF	XOR
Query Zoom Position	0xA0	Address	0x00	0x55	0x00	0x00	0xAF	XOR
Query Zoom Position Response	0xA0	Address	0x00	0x5D	Value High Byte	Value Low Byte	0xAF	XOR

APPENDIX B - DIMENSIONS

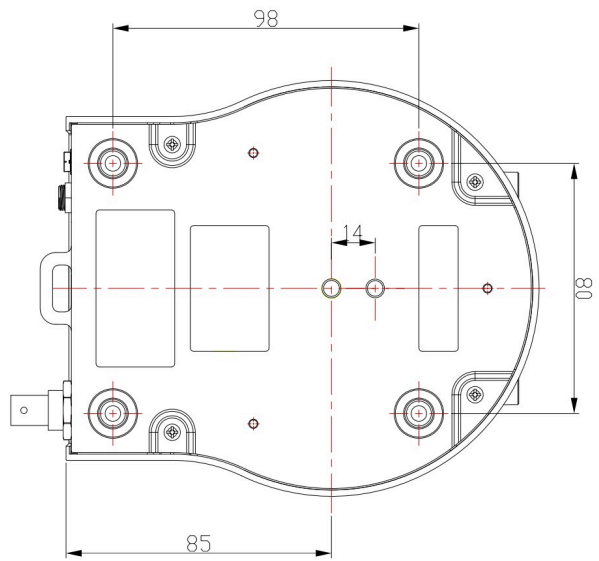
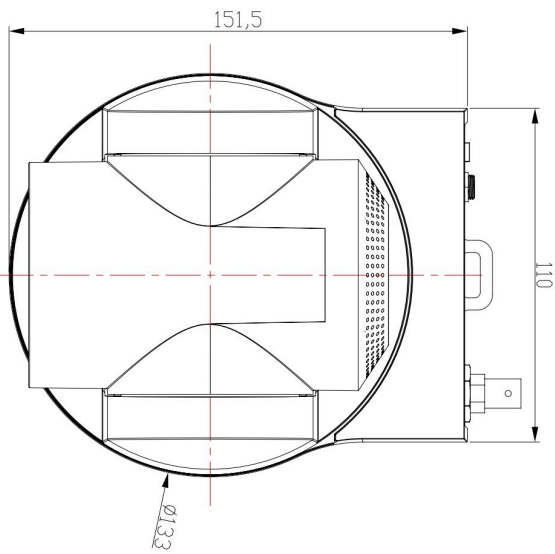
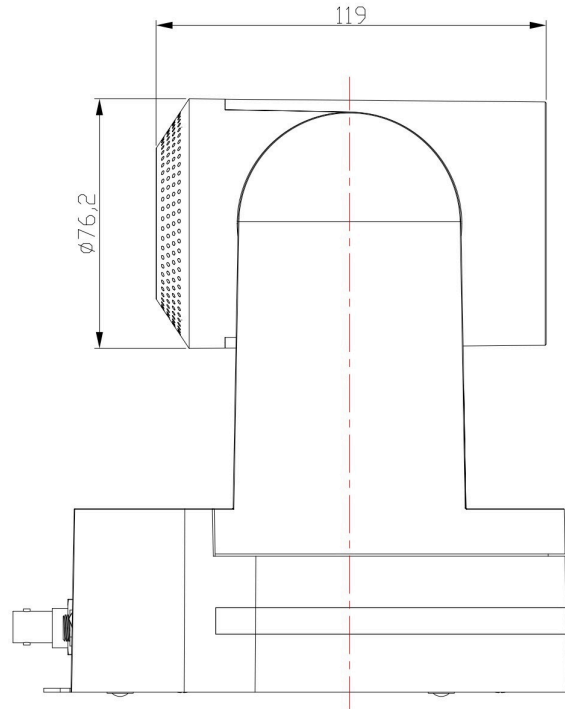
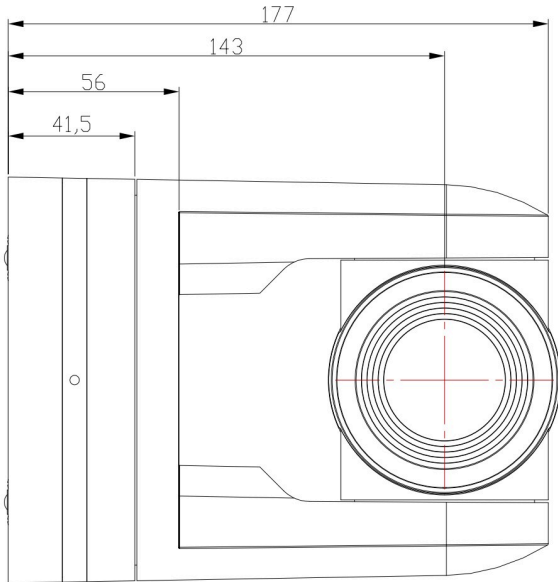

APPENDIX C - HTTP API

With the HTTP API you can control the camera by using a web browser like Microsoft Edge or Google Chrome for example. It is possible to change multiple settings at once using this feature. This document is available as an Appendix in the CM4x manual and as a separate document that can be downloaded on the [product website](#).

How to use HTTP API

To use the HTTP API you need the following link:

<http://192.168.5.126/ajaxcom?szCmd=>



Follow instructions below:

1. Click on the link above, or copy and paste it to your browser.
2. Note that the IP Address in this link is an **example of an IP address**. Change this IP Address to the one you use for your camera. See [Network > Ethernet > IP Address](#).
3. Copy the code from the list. Remember that some codes are documented over **multiple lines** and that you need to **copy this from the first to the last bracket!** See the example below:

Function	Code	Command	Setting
Enable	<code>{\"SetEnv\":{\"StreamPublish\":{\"stMaster\":{\"wHostPort\":1935,\"bEnable\":1,\"nProtoType\":3,\"nChannel\":0}}}</code>	bEnable	0: off 1: on
Protol Type		nProtoType	2: srt 3: rtmp
Host Address	<code>{\"SetEnv\":{\"StreamPublish\":{\"stMaster\":{\"wHostPort\":1935,\"nProtoType\":3,\"szHostUrl\":\"192.168.5.12\"},\"nChannel\":0}}}</code>	szHostUrl	user-defined
Host Port	<code>{\"SetEnv\":{\"StreamPublish\":{\"stMaster\":{\"wHostPort\":19355,\"nProtoType\":3,\"nChannel\":0}}}</code>	wHostPort	[0,65535]
Stream Name	<code>{\"SetEnv\":{\"StreamPublish\":{\"stMaster\":{\"wHostPort\":19355,\"nProtoType\":3,\"szStreamName\":\"live/1213\"},\"nChannel\":0}}}</code>	szStreamName	user-defined
User Name	<code>{\"SetEnv\":{\"StreamPublish\":{\"nProtoType\":3,\"szUserNa</code>	userName	user-defined
Password	<code>{\"SetEnv\":{\"StreamPublish\":{\"nProtoType\":3,\"szPasswo</code>	password	user-defined
SrtKey (SRT Effectie)	<code>{\"SetEnv\":{\"StreamPublish\":{\"wHostPort\":19355,\"nProt</code> <code>\"0123456789\"},\"nChannel</code>	srtKey	user-defined
SrtKeyLen (SRTEffectie)	<code>{\"SetEnv\":{\"StreamPublish\":{\"nProtoType\":3,\"wSrtKeyL</code>	srtKeyLen	[0-32]

RTP Multicast

4. Paste the code at the end of HTTP link. It will look like this:

[192.163.5.126/ajaxcom?szCmd={\"SysCtrl\":{\"PtzCtrl\":{\"nChannel\":0,\"szPtzCmd\":\"left_start\",\"byValue\":50}}}}](http://192.163.5.126/ajaxcom?szCmd={\)

5. Change the settings in the link. In this case:

[192.163.5.126/ajaxcom?szCmd={\"SysCtrl\":{\"PtzCtrl\":{\"nChannel\":0,\"szPtzCmd\":\"left_start\",\"byValue\":50}}}}](http://192.163.5.126/ajaxcom?szCmd={\)

6. Press **ENTER**. If **correct**, you get in return:

[192.163.5.126/ajaxcom?szCmd={\"SysCtrl\":{\"PtzCtrl\":{\"nChannel\":0,\"szPtzCmd\":\"left_start\",\"byValue\":50}}}}](http://192.163.5.126/ajaxcom?szCmd={\)
`{\"nRetVal\":0, \"szError\":\"\"}`

If **failed**, you get in return.

[192.163.5.126/ajaxcom?szCmd={\"SysCtrl\":{\"PtzCtrl\":{\"nChannel\":0,\"szPtzCmd\":\"left_start\",\"byValue\":50}}}}](http://192.163.5.126/ajaxcom?szCmd={\)
`{\"nRetVal\":-1879048185, \"szError\":\"\"}`

7. In case of a failed return, check the following:
 - Brackets in the code. Have you copy and paste the first and the last bracket?
 - Syntax errors in the code/ correct numbers in the key values. Some camera settings are having a specific range. The SRT key for example has a range of 0 - 32. If you have typed 33 it would exceed the range of this key.
 - No long white spaces between the key values of the code. For example this " code " is error and this "code" is right.
 - If you have typed the correct IP address of the camera.
8. If you have done it correct, you can check the settings you have changed in the WebGUI of the camera.

Curl

It is also possible to change the camera settings at once by using the **Command Prompt** from Windows.



Follow instructions below:

1. Click on **Start** in the left corner of your screen in Windows.
2. Type **Notepad** and open this application.
3. Copy and paste the following http link: <http://192.168.5.126/ajaxcom> and the **code** in the [HTTP API code list](#) in **Notepad**.
4. Type **curl**, change the default IP address in the IP Address of your camera, and surround it by quotation marks.
5. Add **--data-raw** between the http link and the code.
6. Type **szCmd** and surround it by quotation marks.
7. **Double** the quotation marks between the brackets! See the example below.

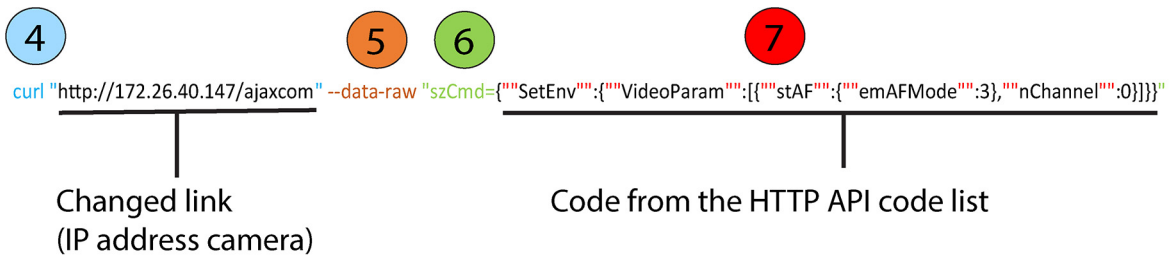

8. Modify the parameters in the code. In the example above **EmAFmode:3** and **nChannel:0** See the [HTTP API code list](#).
9. Click on **Start** in Windows again, type **CMD** and press **Enter**.
10. Copy and paste the link/ code from notepad in **Command Prompt** and press **Enter**.
11. If correct it returns: `{'nRetVal':0, 'szError':''}`

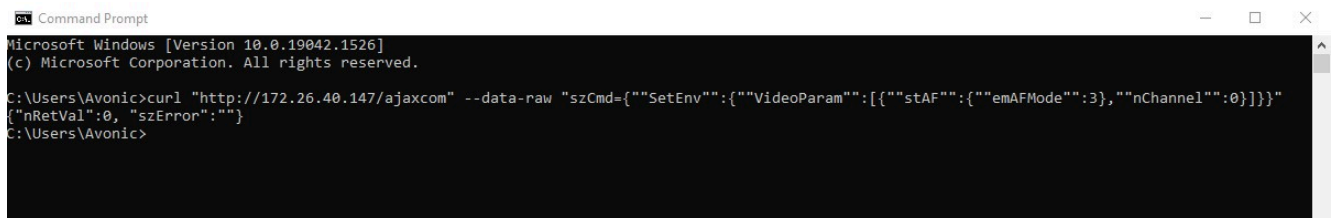

```

Microsoft Windows [Version 10.0.19042.1526]
(c) Microsoft Corporation. All rights reserved.

C:\Users\Avonic>curl "http://172.26.40.147/ajaxcom" --data-raw "szCmd={""SetEnv"";{""VideoParam"":[{""stAF"";{""emAFMode"":3, ""nChannel"":0}]}"
{"nRetVal":0, "szError":""}
C:\Users\Avonic>
  
```

{'GetEnv'}

You can also use the HTTP API to **display the current settings** of the camera in your browser or in the **Command Prompt** application. To do this, you need the {'GetEnv'} codes from the HTTP API code list. If correct you get the following result:



```

{
  "nRetVal": 0,
  "stValue": [
    {
      "stSlave": {
        "wHostPort": 1935,
        "szHostUrl": "172.40.26.147",
        "nProtolType": 2,
        "szStreamName": "live/av1",
        "bEnable": 0,
        "nAbProtolMask": 1,
        "szSrtKey": "",
        "wSrtKeyLen": 0,
        "szUserName": "",
        "szPassword": ""
      },
      "stMaster": {
        "wHostPort": 1935,
        "szHostUrl": "172.40.26.147",
        "nProtolType": 3,
        "szStreamName": "live/av0",
        "bEnable": 0,
        "nAbProtolMask": 1,
        "szSrtKey": "1111111111",
        "wSrtKeyLen": 0,
        "szUserName": "",
        "szPassword": ""
      },
      "nChannel": 0
    }
  ]
}

```

Web browser

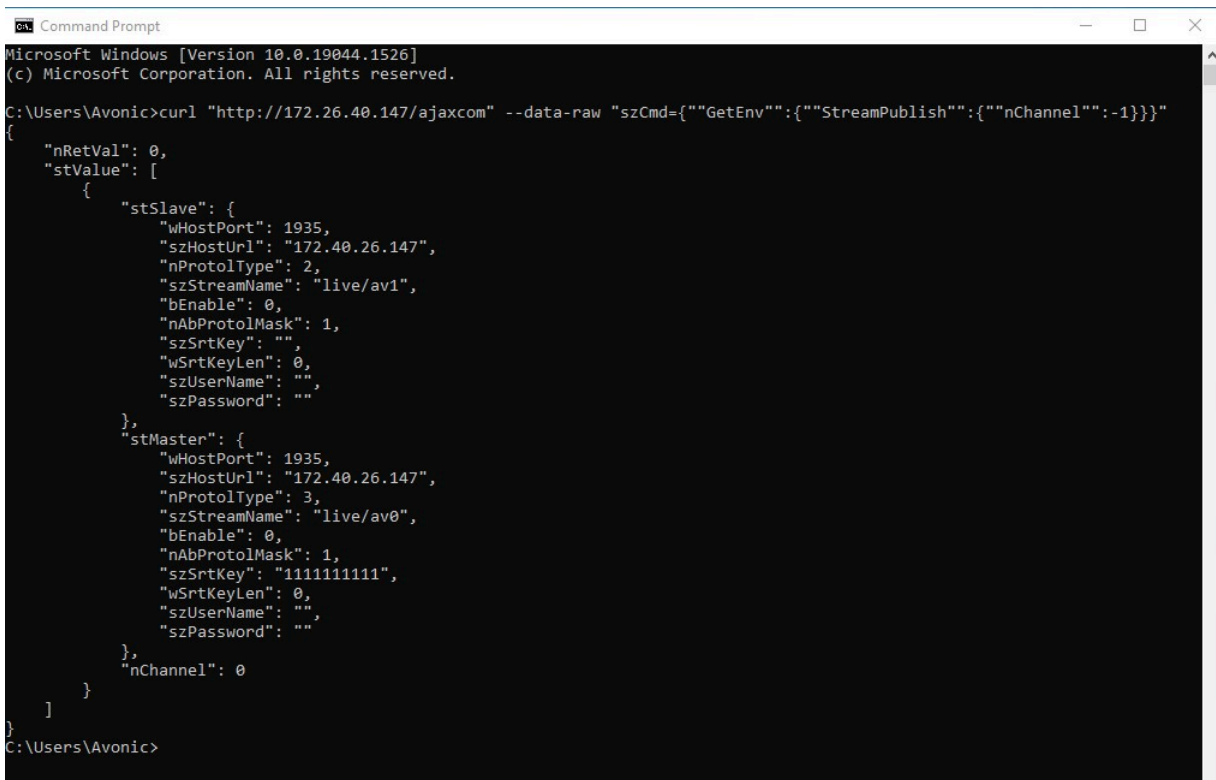

```

C:\Users\Avonic>curl "http://172.26.40.147/ajaxcom" --data-raw "szCmd={'"GetEnv"'":{"StreamPublish":{"nChannel":-1}}}"
{
  "nRetVal": 0,
  "stValue": [
    {
      "stSlave": {
        "wHostPort": 1935,
        "szHostUrl": "172.40.26.147",
        "nProtolType": 2,
        "szStreamName": "live/av1",
        "bEnable": 0,
        "nAbProtolMask": 1,
        "szSrtKey": "",
        "wSrtKeyLen": 0,
        "szUserName": "",
        "szPassword": ""
      },
      "stMaster": {
        "wHostPort": 1935,
        "szHostUrl": "172.40.26.147",
        "nProtolType": 3,
        "szStreamName": "live/av0",
        "bEnable": 0,
        "nAbProtolMask": 1,
        "szSrtKey": "1111111111",
        "wSrtKeyLen": 0,
        "szUserName": "",
        "szPassword": ""
      },
      "nChannel": 0
    }
  ]
}
C:\Users\Avonic>

```

Command Prompt

HTTP API code list

IR Remote Control

IR Enable/Disable			
Command	Code	Command	Setting
szCmd	{"SetEnv":{"ArmPtz":{"blCtrlEnable":0}}}	blCtrlEnable	0: ON
			1: OFF

PTZ

PTZControl			
Code: http://192.168.5.126/ajaxcom?szCmd={"SysCtrl":{"PtzCtrl":{"nChanel":0,"szPtzCmd":"left_start","byValue":50}}}			
Command	Setting	Function	Command
nChanel	0		
byValue	0,100 used to control the speed of ptz		
szPtzCmd			
		left start	left_start
		left stop	left_stop
		leftup start	leftup_start
		leftup stop	leftup_stop
		leftdown start	leftdown_start
		leftdown stop	leftdown_stop
		rightstart	right_start
		rightstop	right_stop
		rightup start	rightup_start
		rightdown start	rightdown_start
		rightdown stop	rightdown_stop
		upstart	up_start
		upstop	up_stop
		downstart	down_start
		downstop	down_stop

PTZ speed

Set PTZ Speed			
Command	Code	Command	Setting
szCmd	{"SetEnv":{"PTZSpeed":{"nPTZSpeed":1}}}	nPTZSpeed	0: Slow
			1: High

Speed by Zoom

Set Speed By Zoom			
Command	Code	Command	Setting
szCmd	{'SetEnv':{'ArmPtz':{'bSpeedByZoom':0}}}	bSpeedByZoom	1: on 0: off

Low power mode

Set Low Power Mode			
Command	Code	Command	Setting
szCmd	{'SetEnv':{'ArmPtz':{'emLowPowerMode':0}}}	emLowPowerMode	2: on 3: off

Zoom Speed

Set Zoom Speed			
Command	Code	Command	Setting
szCmd	{'SetEnv':{'ArmPtz':{'nZoomSpeed':0}}}	nZoomSpeed	0 - 7

Preset Pan Speed

Set Preset Pan Speed			
Command	Code	Command	Setting
szCmd	{'SetEnv':{'ArmPtz':{'nPresetPanSpeed':0}}}	nPresetPanSpeed	0 - 24

Preset Tilt Speed

Set Preset Tilt Speed			
Command	Code	Command	Setting
szCmd	{'SetEnv':{'ArmPtz':{'nPresetTiltSpeed':0}}}	nPresetTiltSpeed	0 - 20

Preset Zoom Speed

Set Preset Zoom Speed			
Command	Code	Command	Setting
szCmd	{'SetEnv':{'ArmPtz':{'nPresetZoomSpeed':0}}}	nPresetZoomSpeed	0 - 7

Focus Mode

Focus Mode Commands	
Focus Mode	
Code	{'SetEnv':{'VideoParam':{'stAF':{'emAFMode':3},'nChannel':0}}}
Command	Setting
nChanel	0
emAFMode	2: Auto
	3: Manual
	4 OnePush
Zoom and focus	
Code	{'SysCtrl':{'PtzCtrl':{'nChannel':0,'szPtzCmd':'zoomdec_start','byValue':0}}}

Focus Mode Commands			
Command	Setting	Function	Command
nChanel	0		
byValue	0		
szPtzCmd			
		Zoom add start	zoomadd_start
		Zoom add stop	zoomadd_stop
		Zoom decrease start	zoomdec_start
		Zoom decrease stop	zoomdec_stop
		Focus add start	focusadd_start
		Focus add stop	focusadd_stop
		Focus decrease start	focusdec_start
		Focus decrease stop	focusdec_stop

Preset

Preset Commands			
Code	{"SysCtrl":{"PtzCtrl":{"nChanel":0,"szPtzCmd":"preset_set","byValue":0}}}		
Command	Setting	Function	Command
nChanel	0s		
ByValue	0, 254		
szPtzCmd			
		Set preset	preset_set
		Call preset	preset_call
		Clean preset	preset_clean

Audio

Audio Configure			
Get audio configure			
Code	{"GetEnv":{"Audio":{}}}		
Set audio configure			
Code	{"SetEnv":{"Audio":{"nSampleBits":16,"nAudioSmstMask":[33554888,33554888,33554433],"bEnable":0,"nlmpVolume":4,"nBitRate":64,"nAEncType":7,"byAudioCodeclst":[6,7,2],"nSampleRate":44100,"nChannel":1}}}		
Function	Code	Command	Setting
Enable	{"SetEnv":{"Audio":{"bEnable":1}}}	bEnable	0: off 1: on
Encode Type	{"SetEnv":{"Audio":{"nAEncType":7}}}	nAEncType	6: Mp3AAC 7: G.711A 2:
Sample Rate	{"SetEnv":{"Audio":{"nSampleRate":32000}}}	nSampleRate (Only supporting these sample rates and gyl1a can only be 8000.)	16000 32000 44100 48000

Audio Configure				
Sample Bits	{'SetEnv':{'Audio':{'nSampleBits':16}}}	nSampleBits	16	
Bit Rate	{'SetEnv':{'Audio':{'nBitRate':96}}}	nBitRate	32 48	64 96 128
Channel	{'SetEnv':{'Audio':{'nChannel':2}}}	nChannel	1: Mono	2: Stereo
Input Volume	{'SetEnv':{'Audio':{'nInpVolume':5}}}	nInpVolume (range 1 to 10)	Exp:[1, 10]	

Video

Camera Settings

Video Parameters				
Get video parameters				
Code	{'GetEnv':{'VideoParam':{'nChannel':-1}}}			
Set video parameters				
Focus				
Function	Code	Command	Setting	
Focus Mode	{'SetEnv': {'VideoParam':{'stAF': {'emAFMode':2,'nChannel':0}}}}	emAFMode	2: Auto 3: Manual 4: OnePush	
AF-Zone	{'SetEnv': {'VideoParam':{'stAF': {'emAFZone':1,'nChannel':0}}}}	emAFZone	0: Front Focus 1: Back Focus 2: Meeting 3: Education Tracking 4: Moving Objects 5: Center Focus	
AF-Sensitivity	{'SetEnv': {'VideoParam':{'stAF': {'nSensitivity':1,'nChannel':0}}}}	nSensitivity	1: High 2: Middle 3: Low	

Exposure

Camera Settings				
Exposure				
Mode	{'SetEnv':{'VideoParam':{'stExp':{'stExpMode': {'emExpMode':0}, "nChannel":0}}}}	emExpMode	0: 3: 10: 11: 13:	Auto Manual SAE AAE Bright
Exposure: Auto				
EV	{'SetEnv':{'VideoParam':{'stExp': {'expcomp_mode':2,'nChannel':0}}}}	expcomp_mode	2: 3:	ON OFF
EV Level	{'SetEnv':{'VideoParam':{'stExp': {'expcomp':8,'nChannel':0}}}}	expcomp	[0, 14]	

Camera Settings				
BLC	{'SetEnv':{'VideoParam':{'stExp': {'backlight':2,'nChannel':0}}}}	backlight	2: 3:	ON OFF

Camera Settings				
Exposure: Auto				
Function	Code	Command	Setting	
Flicker	{'SetEnv':{'VideoParam':{'stExp': {'antiflicker':0,'nChannel':0}}}}	antiflicker	0: 1: 2:	OFF 50HZ 60HZ
G.Limit	{'SetEnv':{'VideoParam':{'stExp': {'gainLimit':5,'nChannel':0}}}}	gainLimit	[0, 15]	
DRC	{'SetEnv':{'VideoParam':{'stExp': {'drc':6,'nChannel':0}}}}	drc	[0, 8]	
Exposure: Manual				
shutter	{'SetEnv':{'VideoParam':{'stExp':{'stShutter': {'nShutter':16},'nChannel':0}}}}	nShutter	[0, 16]	
Iris	{'SetEnv':{'VideoParam':{'stExp':{'stIris': {'nIris':12},'nChannel':0}}}}	nIris	[0, 12]	
DRC	{'SetEnv':{'VideoParam':{'stExp': {'drc':8,'nChannel':0}}}}	drc	[0, 8]	
Exposure: SAE				
shutter	{'SetEnv':{'VideoParam':{'stExp':{'stShutter': {'nShutter':16},'nChannel':0}}}}	nShutter	[0, 16]	
DRC	{'SetEnv':{'VideoParam':{'stExp': {'drc':7,'nChannel':0}}}}	drc	[0, 8]	

Camera Settings				
Exposure: AEE				
Function	Code	Command	Setting	
Flicker	{'SetEnv':{'VideoParam':{'stExp': {'antiflicker':0,'nChannel':0}}}}	Antiflicker	0: 1: 2:	OFF 50HZ 60HZ
G.Limit	{'SetEnv':{'VideoParam':{'stExp': {'gainLimit':5,'nChannel':0}}}}	gainLimit	[0, 15]	
Iris	{'SetEnv':{'VideoParam':{'stExp':{'stIris': {'nIris':12},'nChannel':0}}}}	nIris	[0, 12]	
DRC	{'SetEnv':{'VideoParam':{'stExp': {'drc':6,'nChannel':0}}}}	drc	[0, 8]	
Exposure: Bright				
Bright	{'SetEnv':{'VideoParam':{'stExp': {'bright':0,'nChannel':0}}}}	bright	[0, 23]	
Flicker, G.Limit, DRC	You can find the same configure at AAE			

Color and Image

Camera Settings						
Color						
Function	Code	Command	Setting			
WB Mode	{\"SetEnv\":{\"VideoParam\":{\"stColor\":{\"emWbMode\":0},\"nChannel\":0}}}	emWbMode	0:	Auto	10:	6000K
			1:	3000K	6:	6500K
			7:	3500K	11:	7000K
			2:	4000K	5:	Manual
			8:	4500K	3:	OnePush
			4:	5000K		
			9:	5500K		
RG Tuning	{\"SetEnv\":{\"VideoParam\":{\"stColor\":{\"rgaintuning\":0},\"nChannel\":0}}}	rgaintuning	[0, 20]			
BG Tuning	{\"SetEnv\":{\"VideoParam\":{\"stColor\":{\"bgaintuning\":20},\"nChannel\":0}}}	bgaintuning	[0, 20]			
Saturation	{\"SetEnv\":{\"VideoParam\":{\"stColor\":{\"saturation\":0},\"nChannel\":0}}}	saturation	[0, 14]			
Hue	{\"SetEnv\":{\"VideoParam\":{\"stColor\":{\"hue\":14},\"nChannel\":0}}}	hue	[0, 14]			
AWB Sensitivity	{\"SetEnv\":{\"VideoParam\":{\"stColor\":{\"awbsens\":0},\"nChannel\":0}}}	awbsens	0:	Low		
			1:	Middle		
			2:	High		
Image						
Bright	{\"SetEnv\":{\"VideoParam\":{\"stImg\":{\"luminance\":0},\"nChannel\":0}}}	luminance	[0, 4]			
Contrast	{\"SetEnv\":{\"VideoParam\":{\"stImg\":{\"contrast\":0},\"nChannel\":0}}}	contrast	[0, 14]			
Sharpness	{\"SetEnv\":{\"VideoParam\":{\"stImg\":{\"sharpness\":1},\"nChannel\":0}}}	sharpness	[0, 15]			
Gamma	{\"SetEnv\":{\"VideoParam\":{\"stImg\":{\"gamma\":0},\"nChannel\":0}}}	gamma	[0, 4]			
					0:	Default
					1:	0.45
					2:	0.50
					3:	0.55
					4:	0.63
DCI	{\"SetEnv\":{\"VideoParam\":{\"stImg\":{\"dci\":0},\"nChannel\":0}}}	dci	[0, 8]			
			0:			OFF
B&W Mode	{\"SetEnv\":{\"VideoParam\":{\"stImg\":{\"nBWMode\":0},\"nChannel\":0}}}	nBWMode	0:	Color		
			4:	B & W		
Flip-H	{\"SetEnv\":{\"VideoParam\":{\"stImg\":{\"nFlipH\":3},\"nChannel\":0}}}	nFlipH	2:	ON		
			3:	OFF		

Camera Settings				
Image				
Function	Code	Command	Setting	
Flip-V	{'SetEnv':{'VideoParam':{'stImg':{'nFlipV':2,'nChannel':0}}}}	nFlipV	2: 3:	ON OFF
AutoFlip	{'SetEnv':{'VideoParam':{'stImg':{'nAutoFlipV':2,'nChannel':0}}}}	nAutoFlipV		ON OFF
DZoom	{'SetEnv':{'VideoParam':{'stImg':{'nEZoom':3,'nChannel':0}}}}	nEZoom	2: 3:	ON OFF

Noise Reduction

Camera Settings				
Function	Code	Command	Setting	
NR-2D	{'SetEnv':{'VideoParam':{'stNR':{'noise2D':0,'nChannel':0}}}}	noise2D	[0, 8]	
NR-3D	{'SetEnv':{'VideoParam':{'stNR':{'noise3D':0,'nChannel':0}}}}	noise3D	[0, 8]	0: OFF 8: Auto
Dynamic Hot Pixel	{'SetEnv':{'VideoParam':{'stNR':{'dhotpixel':3,'nChannel':0}}}}	dhotpixel	[0, 5]	0: OFF
Style	{'SetEnv':{'VideoParam':{'stColor':{'nStyleInx':0,'nChannel':0}}}}	nStyleInx	[0, 4]	0: Default 1: Normal 2: Clarity 3: Bright 4: Soft

Output Format



Take note that the Video Format over USB is dictated by the computer it is connected with and will **NOT** work! However, using a HDMI connection in a **CM40 camera**, you can set the Video Format. Since the CM44/ CM41 has no HDMI port, this will NOT work in a CM44/ CM41 camera.

(Video) Output Format				
Get video out parameters				
Code	{'GetEnv':{'VideoOut':{'nChannel':-1}}}			
Set video out parameters				
Code	{'SetEnv':{'VideoOut':{'nNetMode':2,'emVoutFormat':9,'byFormatList':[10,9,4,3,8,7,6,5,26,25,20,21,22,23,24]}}			
Function	Code	Command	Setting	
		nNetMode: default value 2, do not modify it	– HD output – HD output + SD network – SD output + HD network	

(Video) Output Format				
		emVoutFormat: Setting the current video out format.	10: 9: 4: 3:	1080P60 1080P50 1080P30 1080P25
			8:	1080I60
			7:	1080I50
			6:	720P60
			5:	720P50
			26:	720P30
			25:	720P25
			20:	1080P59.94
			21:	1080I59.94
			22:	1080P29.97
			23:	720P59.94
			24:	720P29.97

Network

Network configure and port settings



Take note that using the GetEnv code you will get in return the port settings of multiple ports. Since only the Visca Port can be set in a CM40 series camera, the settings of other ports have no use in this type of camera.

Network Configure			
Get network port parameters			
Code	{'GetEnv':{'NetWork':{'nChannel':-1}}}		
Set network port parameters			
Code	{'SetEnv':{'NetWork':{'stNetPort':{'wPortVisca':1936}}}}		
Port Settings			
Function	Code	Command	Setting
Port Visca		wPortVisca	[0, 65535]

Ethernet

Ethernet			
Get Ethernet parameters			
Code	{'GetEnv':{'NetWork':{'nChannel':-1}}}		
Set Ethernet parameters			
Code	"SetEnv':{'NetWork':{'stEth': [{'byValid':5,'szIPAddr':'192.168.5.126','szSubMask':'255.255.255.0','szMacAddr':'E4:77:D4:01:8A:49', 'szGateway':'192.168.5.1','bDefault':1}}]}		
Function	Code	Command	Setting

Ethernet			
DHCP	{'SetEnv':{'NetWork':{'stEth':{'byValid':5}}}}	byValid	5:off 7:on
IP Address	{'SetEnv':{'NetWork':{'stEth':{'szIPAddr':'192.168.5.127'}}}}		
Subnet Mask	{'SetEnv':{'NetWork':{'stEth':{'szSubMask':'255.255.255.0'}}}}		
Default Gateway	{'SetEnv':{'NetWork':{'stEth':{'szGateway':'192.168.5.1'}}}}		

DNS

DNS			
Get dns parameters			
Code	{'GetEnv':{'NetWork':{'hChannel':-1}}}		
Set dns parameters			
Code	{'SetEnv':{'NetWork':{'stDns':{'szDns1':'8.8.8.8','szDns2':'0.0.0.0'}}}}		
Function	Code	Command	Setting
Preferred DNS Server	{'SetEnv':{'NetWork':{'stDns':{'szDns1':'8.8.8.8'}}}}		
Alternative DNS Server	{'SetEnv':{'NetWork':{'stDns':{'szDns2':'8.8.8.8'}}}}		

System

System Configure			
Get sysattr parameters			
Code	{'GetEnv':{'SysAttr':{'hChannel':-1}}}		
Set sysattr parameters			
Code	{'SetEnv':{'SysAttr':{'nLanguage':0,'szDeviceID':'1','emVideoStandard':1,'szDevName':'testname'}}}		
Function	Code	Command	Setting
Device Name		szDevName	user-defined, cannot use white space
Device ID		szDeviceID	cannot modify
Language		nLanguage	0: Simplified Chinese 2: English

User

SysUser			
Get sysuser parameters			
Code	{'GetEnv':{'SysUser':{}}}		
Set sysuser parameters			
Code	{'SetEnv':{'SysUser':{'stUsers':{'nUserType':0,'szUserName':'admin','szPassword':'admin'},{'nUserType':1,'szUserName':'user1','szPassword':'user1'},{'nUserType':1,'szUserName':'user2','szPassword':'user2'}}}}		
Function	Code	Command	Setting
Authority		nUserType	0: admin 1: user1 or user 2

SysUser			
User Name		szUserName	user-defined: no white space
Password		szPassword	user-defined, no white space. This command must set three users at the same time.

Update

Update	
Get update parameters	
Code	<code>{"QueryState":{"QueryVersion":{}}}</code>
Code	Get the return value and split it like this: <code>szText.Format("%d.%d.%d-%d-%d", (stVersion.dwCamVersion >> 16) & 0xFF, (stVersion.dwCamVersion >> 8) & 0xFF, (stVersion.dwCamVersion & 0xFF), (stVersion.dwCamDate >> 16) & 0xFFFF, (stVersion.dwCamDate >> 8) & 0xFF, (stVersion.dwCamDate & 0xFF));</code>
Set update parameters	Not supported update with API, you can do this through webpage.

Default and Reboot

Default	
Code	<code>{"SysCtrl":{"Default":{}}}</code>

Reboot	
Code	<code>{"SysCtrl":{"Reboot":{}}}</code>



The URL supports to set all params at one time and also can set one of them through split URL into one other command. Different commands can be found at different settings.

APPENDIX D - CMOS SENSOR CHARACTERISTICS

The following occurrences that may appear in images are specific to CMOS (Complementary Metal Oxide Semiconductor) image sensors. They do not indicate malfunctions.

White Flecks

Although the CMOS image sensors are produced with high-precision technologies, fine white flecks may be generated on the screen in rare cases. These flecks are caused by natural and / or artificial radiation, which causes a “false exposure” on the image sensor. The shape of these spots may vary from dots to lines or other —sometimes irregular— shapes. These spots occur in random locations of the image, occur only in a single frame and are more visible in dark images. This is a principle issue of all image sensors and **is not a malfunction**.

The white flecks especially tend to be seen in the following cases:

- When operating at a high ambient temperature
- When you have raised the gain (sensitivity)

The white flecks may be reduced by turning the camera off, then on again.

Aliasing

When fine patterns, stripes, or lines are shot, they may appear jagged or flickering. **Aliasing** refers to the effect that is produced when a signal is imperfectly reconstructed from the original signal. It occurs when a signal is not sampled at a high enough frequency to create an accurate representation.

This effect is shown in the following example of a **sinusoidal function**:

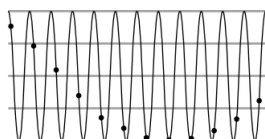

In this example, the dots represent the sampled data and the curve represents the original signal. Because there are not enough sampled data points, the resulting pattern produced by the sampled data is a poor representation of the original.

Focal Plane

Owing to the characteristics of the pickup elements (CMOS image sensors) for reading video signals, subjects that quickly move across the screen may appear slightly skewed (i.e., tilted to the left or right, depending on the direction of camera or subject movement). Since a CMOS sensor typically captures one row at a time within approximately 1/60th or 1/50th of a second (depending on the refresh rate), it may result in a “rolling shutter” effect. In such cases, the image is skewed.

Flash Band

If you film a strobe or quick-flashing light, brightness may differ between the upper and lower halves of the picture. See the Focal Plane explanation above for a clarification of this occurrence.

Flicker

If you are recording under lighting that is produced by discharge tubes (such as fluorescent, sodium or mercury-vapor lamps), the screen may flicker, colors may vary, or horizontal stripes may appear distorted. In such cases, set the anti-flicker setting to 'on'. Depending on lighting types, such occurrences may not be improved with the anti-flicker setting.



It is recommended to set the shutter speed to 1/100s in areas of 50 Hz power supply frequency, and to 1/60s in areas of 60 Hz power supply frequency.

APPENDIX E - DATASHEET SPECIFICATIONS

SPECIFICATIONS

Camera

Video Systems	1080p30 16:9/720p30 16:9/ 576p30 16:9/ 540p30 16:9/ 360p30 16:9/ 180p30 16:9/ 768p30 16:9/ 600p30 4:3/ 480p30 4:3
Sensor	1/2.8" CMOS, 2.07mp, 16:09
Shutter	Auto, Manual
Scanning mode	Progressive, Interlaced
Zoom/Aperture/Focal length	5x optical/ F1.8-F11/ 3.1-15.5 mm
Minimal Illumination	0.5 (F1.8, AGC On)
White Balance	Auto, Manual, OnePush, 3000K-7000K in steps of 500K
Backlight Compensation	supported
Digital Noise Reduction	2D & 3D DNR
Signal Noise Ratio	>55 dB
Horizontal FoV wide ~ tele	83.7° ~ 20°
Vertical FoV wide ~tele	53° ~ 11°
Horizontal rotation	-170° ~ +170°
Vertical rotation	-30° ~ +90°
Pan speed range	0.1 ~ 120°/s
Tilt speed range	0.1 ~ 70°/s
H&V image flip	supported
Number of presets	255
Preset accuracy	0.1

Input / Output Interface

USB output	1080p30 USB2.0
Network interface	RJ45 for IP control and FW update
IP control protocol	VISCA OVER IP
Serial communication	RS232 8DIN + RS485 2pin Phoenix
Serial protocol	VISCA, PELCO-P, PELCO-D

General Specifications

Input voltage	12V
PoE	No PoE
Power consumption	12W
Power supply	12V2A
Power connector	EIAJ-3 - Philmore 275 screw lock
Operating temperature	-5°C ~ 40°C
Storage temperature	-20°C ~ 60°C
Operating humidity	20% ~ 95% non-condensing
Bottom fastening screw thread	1/4" 20 UNC
Color	Black
Dimensions product wxhxd	132x180x153mm
Weight product	1.6 kg
Dimensions box	27 x 25 x 23 cm
Weight box	2.5 kg
Included	power adapter, remote control, RS232 cable, USB2.0 cable (A-A), RS485 connector

Index

A

AAE Mode (Aperture Auto Exposure) [27](#), [66](#)
AF Sensitivity [29](#), [30](#), [49](#), [65](#)
AF Version [32](#), [34](#), [71](#)
AF Zone [29](#), [30](#), [50](#), [65](#)
Audio [64](#)
Auto Exposure Mode [26](#)
AWB Mode [28](#)
AWB Sensitivity [28](#), [49](#), [67](#)

B

Baudrate [17](#), [25](#)
BG Tuning [28](#), [40](#), [47](#), [50](#), [67](#)
BLC (Back Light Compensation) [22](#), [26](#), [26](#), [48](#), [66](#)
Bright [47](#)
Bright (Exposure) Mode [28](#), [66](#)
BW (Black and White) Mode [29](#), [67](#)

C

Camera Version [32](#), [34](#), [71](#)
Ceiling Mount (AV-MT250) [15](#)
CMOS [72](#)
Color [28](#), [40](#), [67](#)
COM port [17](#)
Contrast [49](#), [67](#)
Controller [16](#), [17](#), [18](#), [24](#)

D

DC12V [16](#)
DCI (Dynamic Contrast) [29](#), [67](#)
Debug Log [36](#)
Device ID [70](#)
Device Name [70](#)
DHCP [32](#), [33](#), [70](#)
DNS Server [34](#), [70](#)
DRC (Dynamic Range Compression) [26](#), [27](#), [27](#), [66](#)
Dynamic Hot Pixel [30](#), [48](#), [68](#)

E

Ethernet [33](#), [69](#)
EV (Exposure Value) [26](#), [26](#), [65](#)
EV (level) [47](#)
Exposure [26](#), [40](#), [47](#), [65](#)

F

Factory Reset [32](#), [35](#), [49](#), [71](#)
Firmware [32](#), [34](#), [41](#), [50](#), [71](#)
Flicker [26](#), [26](#), [40](#), [48](#), [66](#), [72](#)
Flip-H, Flip-V, Autoflip [29](#), [48](#), [49](#), [67](#)
Focus [21](#), [29](#), [30](#), [36](#), [40](#), [46](#), [63](#), [65](#)

G

G.Limit (Gain Limit) [26](#), [27](#), [47](#), [66](#)
Gamma [29](#), [67](#)

H

HTTP API [59](#)
HTTP Basic Authentication [34](#)
Hue [28](#), [50](#), [67](#)

I

Image Freezing [48](#)
Image Quality [29](#)
IP Address [18](#), [32](#), [33](#), [59](#), [70](#)
IR Remote Control [16](#), [20](#), [23](#), [24](#), [41](#), [62](#)
IR Remote Control Keys [20](#), [23](#)
Iris [26](#), [27](#), [40](#), [47](#), [66](#)

L

LAN [18](#)
Language [25](#), [70](#)
Login [33](#)
Low Power Mode [35](#), [63](#)

M

Manual Exposure Mode [27](#)
MCU Version [32](#), [34](#), [50](#), [71](#)
Mini DIN-8 [17](#)

N

Network [32](#), [41](#), [69](#)
Network Switch [18](#), [19](#)
Noise Reduction [30](#), [40](#), [68](#)
NR-2D [30](#), [48](#), [68](#)
NR-3D [30](#), [48](#), [68](#)

O

OSD (On Screen Display) [22](#), [24](#)

P

Password [18](#), [33](#), [34](#), [71](#)
PELCO [41](#)
PELCO-D [25](#), [56](#)
PELCO-P [25](#), [57](#)
Port [33](#), [69](#)
Power [46](#)
Preset [22](#), [31](#), [35](#), [50](#), [63](#), [64](#)
PTZ [22](#), [31](#), [35](#), [49](#), [62](#)

R

Reboot [35](#), [71](#)
Reboot Schedule [35](#)
RG Tuning [28](#), [40](#), [47](#), [50](#), [67](#)
RJ45 [16](#)
RS-232 [16](#), [17](#), [41](#), [42](#)
RS-485 [16](#), [17](#), [18](#), [41](#)

S

SAE Mode (Shutter Auto Exposure) [27](#), [66](#)
Saturation [28](#), [67](#)
SDI [23](#)
Sharpness [29](#), [48](#), [67](#)
Shutter [26](#), [27](#), [47](#), [66](#)
Speed by Zoom [31](#), [35](#), [63](#)
SRT [59](#)
Style [31](#), [68](#)
System Select [16](#), [23](#)

T

Tally Light [50](#)
TCP [18](#), [42](#)

U

UDP [18](#), [42](#)
USB [16](#), [16](#), [24](#)
Username [18](#), [33](#), [34](#), [71](#)
UVC Version [50](#)

V

Video Format [23](#), [51](#), [68](#)
VISCA [25](#), [41](#), [42](#)
VISCA over IP [42](#)

W

Wall Mount (AV-MT200) [15](#)
WB (White Balance) Mode [28](#), [40](#), [46](#), [67](#)
WebGUI [33](#), [41](#)

Z

Zoom [22](#), [46](#)
Zoom Speed [31](#), [35](#), [63](#)



Video Conference Camera USB2.0 Black
AV-CM44-VCUC

© September 2022 • Version 1.21