

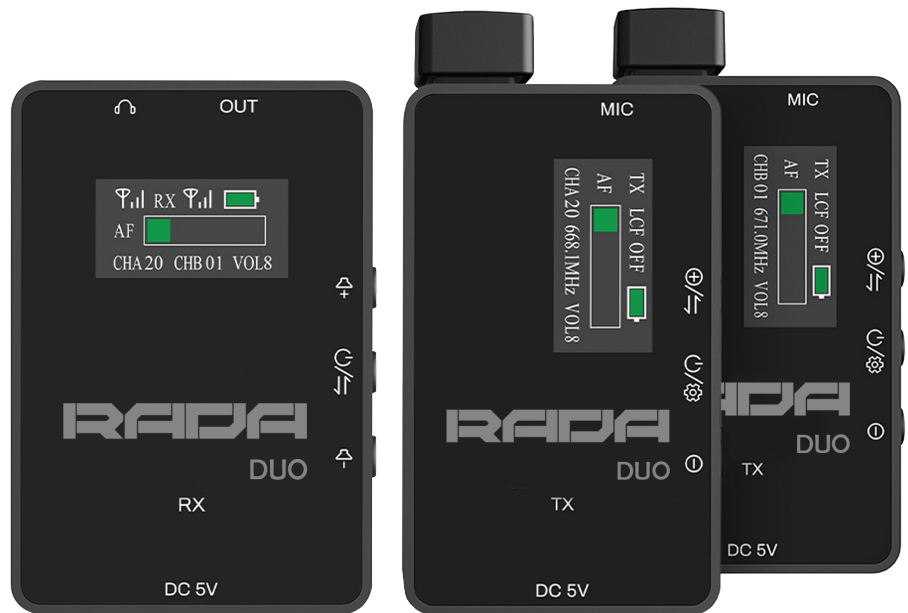

RADA



**CLIP, WALK AND
TALK WITH RADA DUO**

RADA DUO

QUICK INSTALLATION GUIDE

RADA Duo Quick Installation Guide

RADA Duo is a lavalier wireless microphone defined by its miniature and lightweight design, high-quality audio, long battery life and precise noise cancellation with LCF mode for especially loud environments. Duo is focused on flexibility and thus features clips on the receiver and transmitters that can be attached to a jacket, shirt, or belt.

The system relies on UHF wireless transmission – it ensures outstanding signal stability and a professional-level audio quality. RADA Duo is designed as a dual-channel system, able to record two microphone transmitters simultaneously, and also supporting volume monitoring and adjustment via hotkeys.

Duo is primarily designed for usage with AREC Media Stations, allowing users to record presenters' and guests' voices. However, there are other applications for it – you can also use it with cameras and tablets, mobile devices, such as phones, as well as PCs, AV audio mixers and other recording and streaming devices.

WARNINGS



1. Some amount of ambient noise is unavoidable in particularly noisy environments
2. Store in dry and clean place when not in use. Avoid storing in hot and humid locations, as it can affect the product's sensitivity and tone
3. Avoid pulling by the cables and bumping them, since that can cause the microphone sensitivity to drop or damage the cables.
4. Keep the devices dry and avoid touching them with wet hands. RADA Duo is not waterproof, therefore do not expose it to rain or water

PRECAUTIONS

1. Check that all cables are properly inserted when using the devices
2. RADA Duo is equipped with rechargeable lithium batteries that have a certain life limit as is normal for batteries. Over time the maximum working hours will be reduced. You can take the following steps to extend the battery life:
 - Pull out the power cord after the device finishes charging.
 - Fully discharge and fully recharge the batteries at least once every three months

Product Package Includes

- x1 Receiver
- x2 Transmitter microphone
- x1 TRRS to TRRS audio cable
- x1 TRRS to TRS audio cable
- x1 1-to-3 USB Type-C to USB A charging cable
- x2 Lavalier microphones with clips
- x2 Windshields for microphones
- x1 Cold shoe mount for installation on cameras
- x1 Carry bag

RADA Duo Transmitter Microphone

1. Transmission : UHF
2. Voltage : 3.7V lithium battery
3. Current : 100mA@3.8VDC
4. Microphone type : omni-directional
5. Frequency : 650~690MHz
6. Frequency stability : <15ppm
7. Transmission power level : 13dBm/3.8VDC
8. Frequency response : 50Hz~15K Hz
9. Operating distance : 50 meters, depending on the environment
10. Battery capacity : 3.7V/480mAh
11. Time to full charge : 1.5 hours
12. Endurance rating : approximately 4 hours
13. Net weight : approximately 70g
14. Dimensions : 71mm X 37mm X 14mm

RADA Duo Receiver

1. Frequency : 650~690MHz
2. Frequency stability : $< \pm 15\text{ppm}$
3. Distortion : $< 0.5\%$
4. Audio Delay : $< 2.5\text{ms}$
5. Frequency response : 50Hz~15K Hz
6. Sensitivity : $< -105\text{dBm}$
7. Dynamic range : $>85\text{dB}$
8. Operating distance : 50 meters, depending on the environment
9. Battery capacity : 3.7V/800mAh
10. Time to full charge : 2 hours
11. Endurance rating : approximately 6 hours
12. Net weight : approximately 86g
13. Dimensions: 62mm X 42mm X 16mm

Icon Description

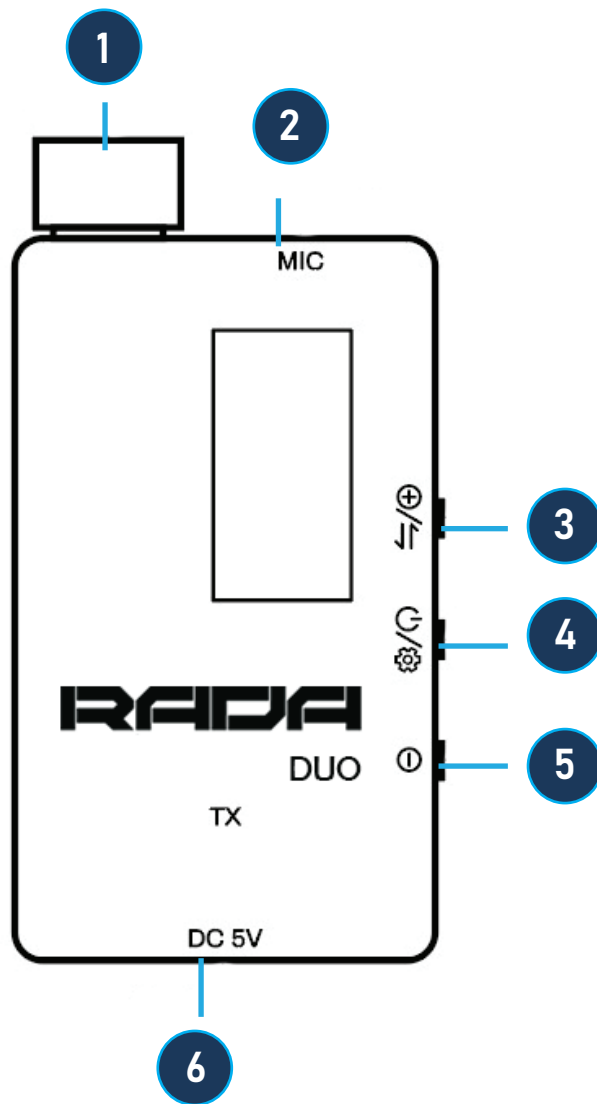

1. Microphone
2. Microphone input : Designed for a 3.5 TRS connector
3. “+” Function key and coding key : Tap to increase when configuring settings or press 3 times in a row to enter coding mode
4. Power button and function key : Press for 2 seconds to turn on or off or tap to scroll through customizable settings
5. “-” Function key : Tap to decrease when configuring
6. Charging port : Designed for USB Type-C, input 5V1A

Icon Description (Launcher TX)

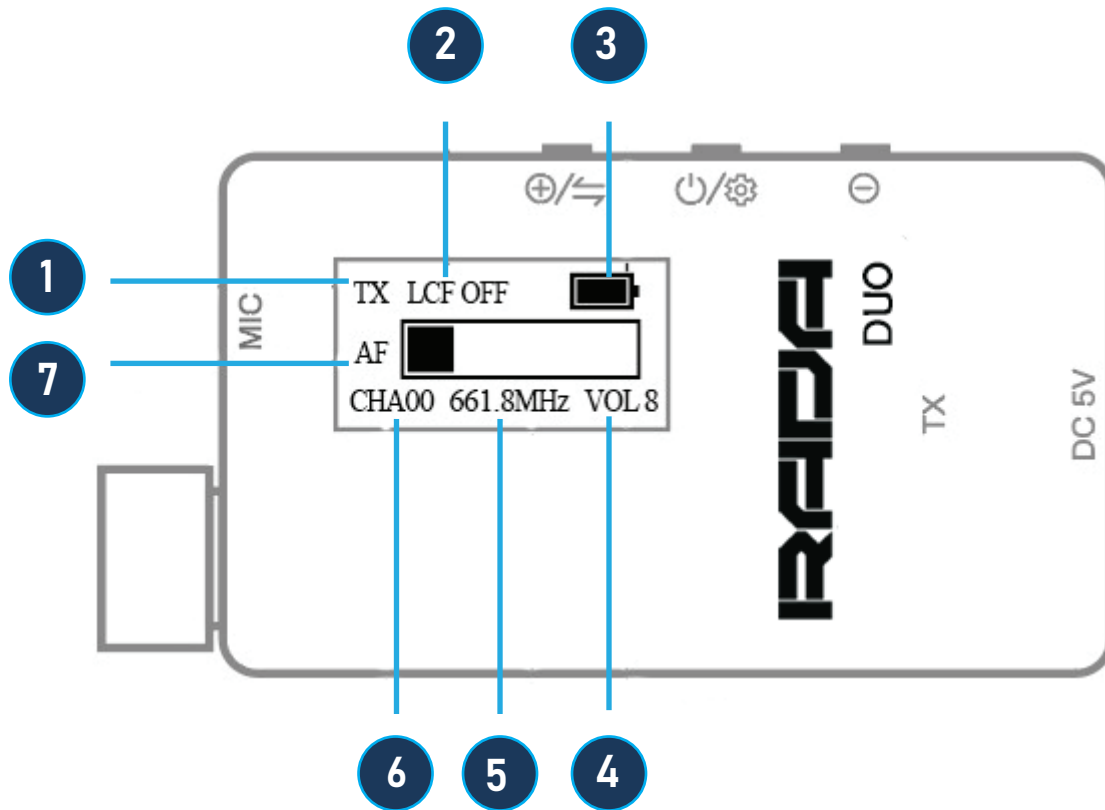

1. TX transmitter icon
2. LCF (low cut filter) : Enable it when in a particularly noisy environment
3. Battery charge indicator : Indicator flashes when charging and stops when fully charged
4. Volume level : You can set it from 0 to 8
5. Frequency : 650 to 690 MHz are supported
6. Channel : 0 to 20 are available
7. Audio Frequency : Dynamically shows audio level

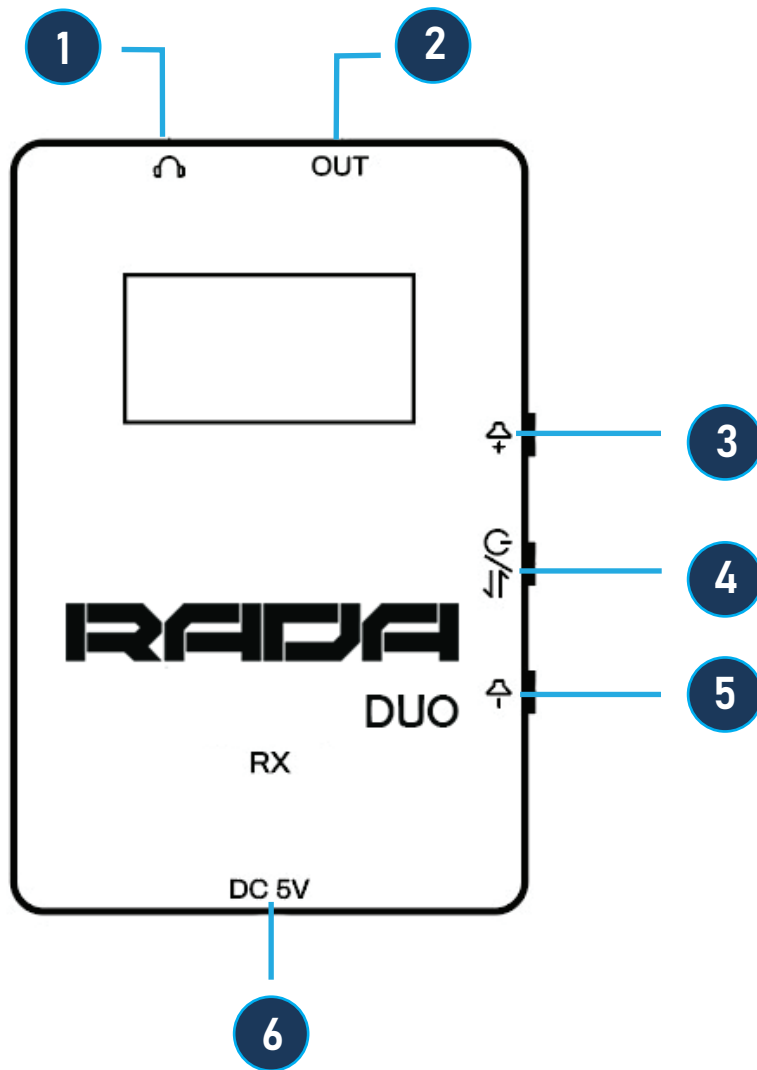

Icon Description

1. Monitoring port : Designed for 3.5 TRS or TRRS headphones
2. Audio output port : Connect to other devices for audio recording via 3.5 TRRS connector
3. Volume “+” control key : When powered on, press to increase volume
4. Power button / coding key : Press for 2 seconds to turn on or off or press 3 times when powered on to enter coding mode
5. Volume “-” control key : When powered on, press to decrease volume
6. Charging port : Designed for USB Type-C, input 5V1A

Icon Description (Receiver RX)

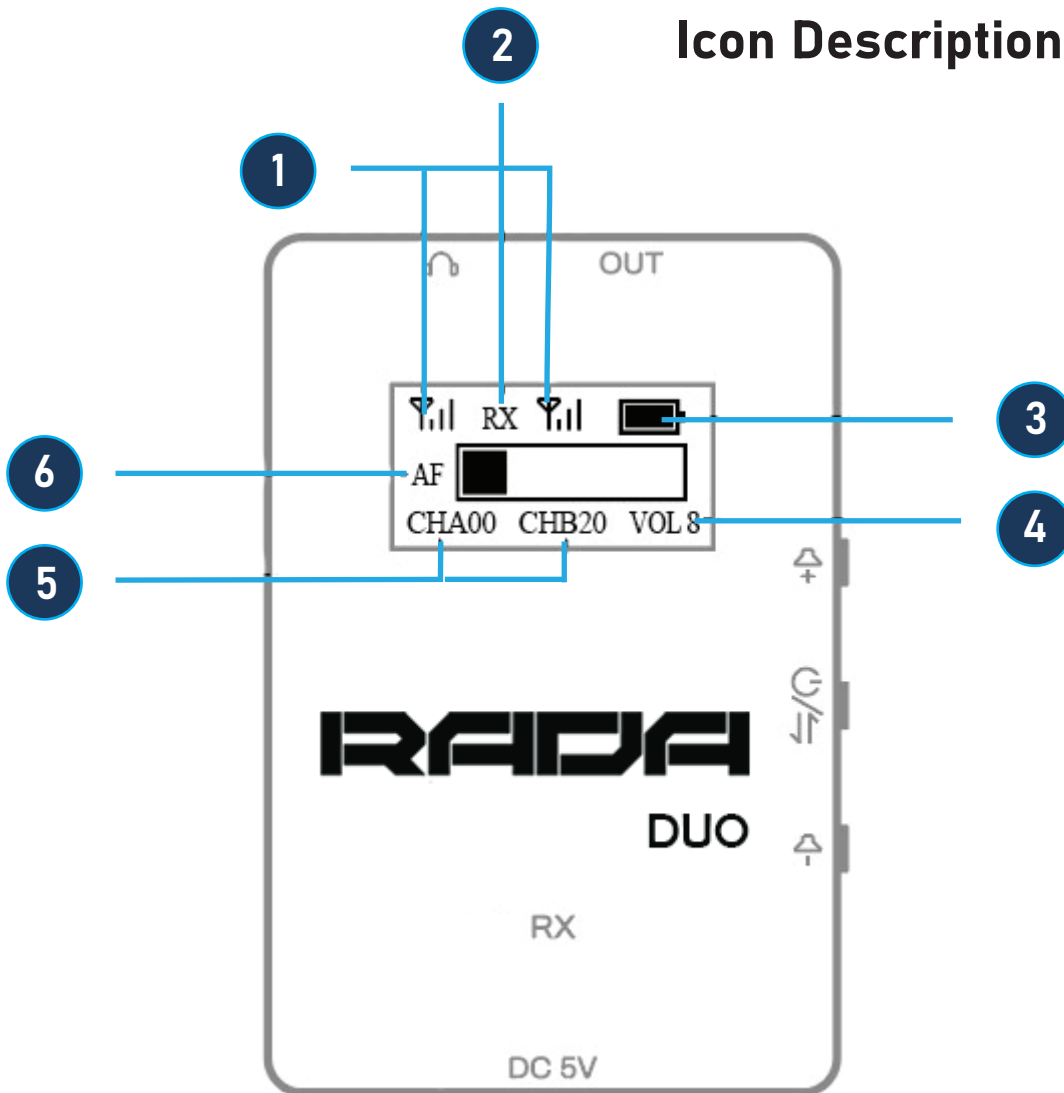

1. Signal strength
2. RX receiver icon
3. Battery charge indicator : Indicator flashes when charging and stops when fully charged
4. Volume level : You can set it from 0 to 8
5. CHA (Channel A) and CHB (Channel B) indicators : 0 to 20 are available
6. Audio Frequency : Dynamically shows audio level

1. 3.5 TRS to 3.5 TRRS for connection to cameras



2. 3.5 TRRS to 3.5 TRRS for connection to cellphones



3. 3.5 TRRS to USB Type-C for connection to computers and mobile devices



4. USB Type C to USB Type A adapter for connection to all standard devices

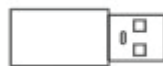

Quick Installation Guide

Transmitter

The transmitter can be used with the inbuilt microphone or with an external 3.5 TRS microphone. If you would like to use an external microphone, input it into the “MIC” port as indicated on the device.

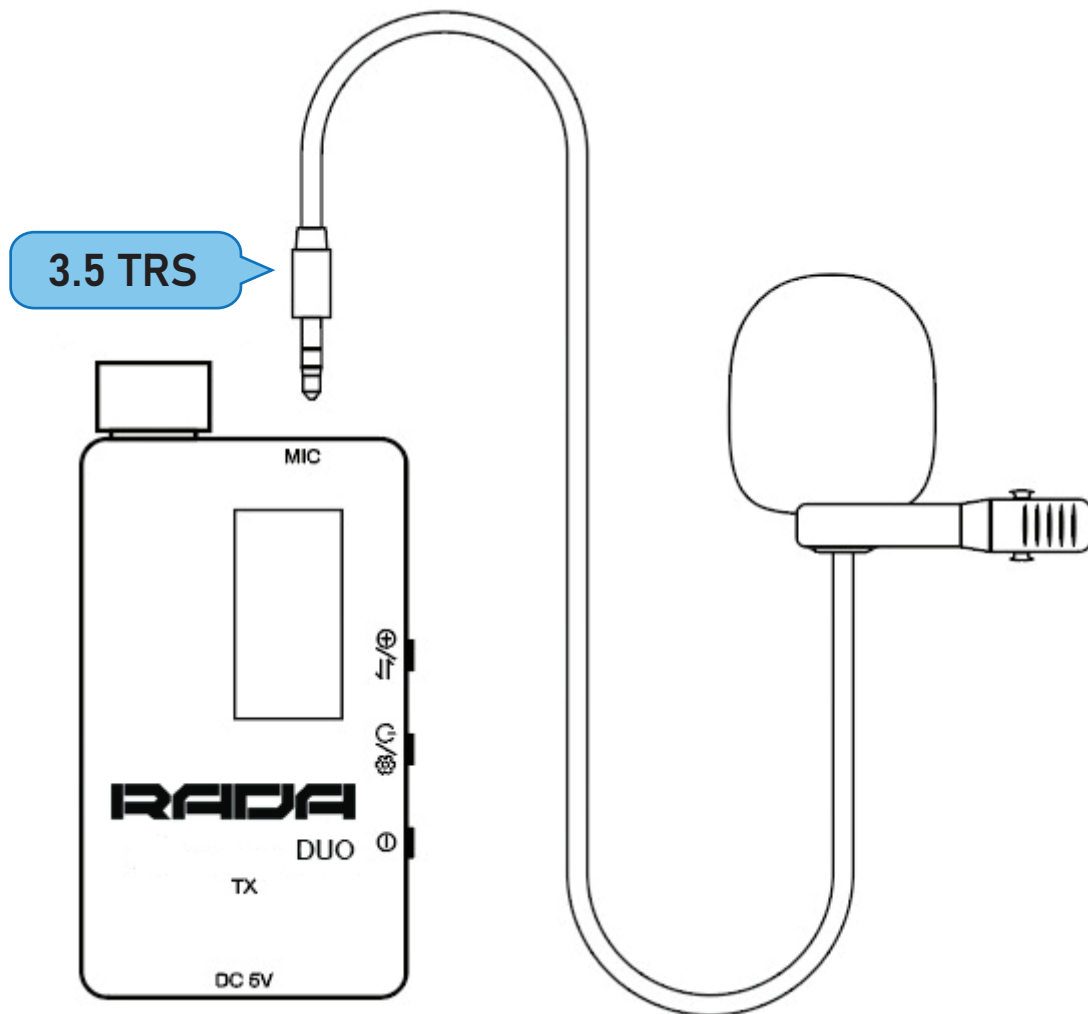

Receiver

The receiver can be connected to a camera using the provided cold shoe like this :

1. Secure the receiver on the cold shoe mount
2. Secure the cold shoe mount on the camera and tighten it
3. Connect the receiver to your camera using the provided 3.5 TRS to 3.5 TRRS cable

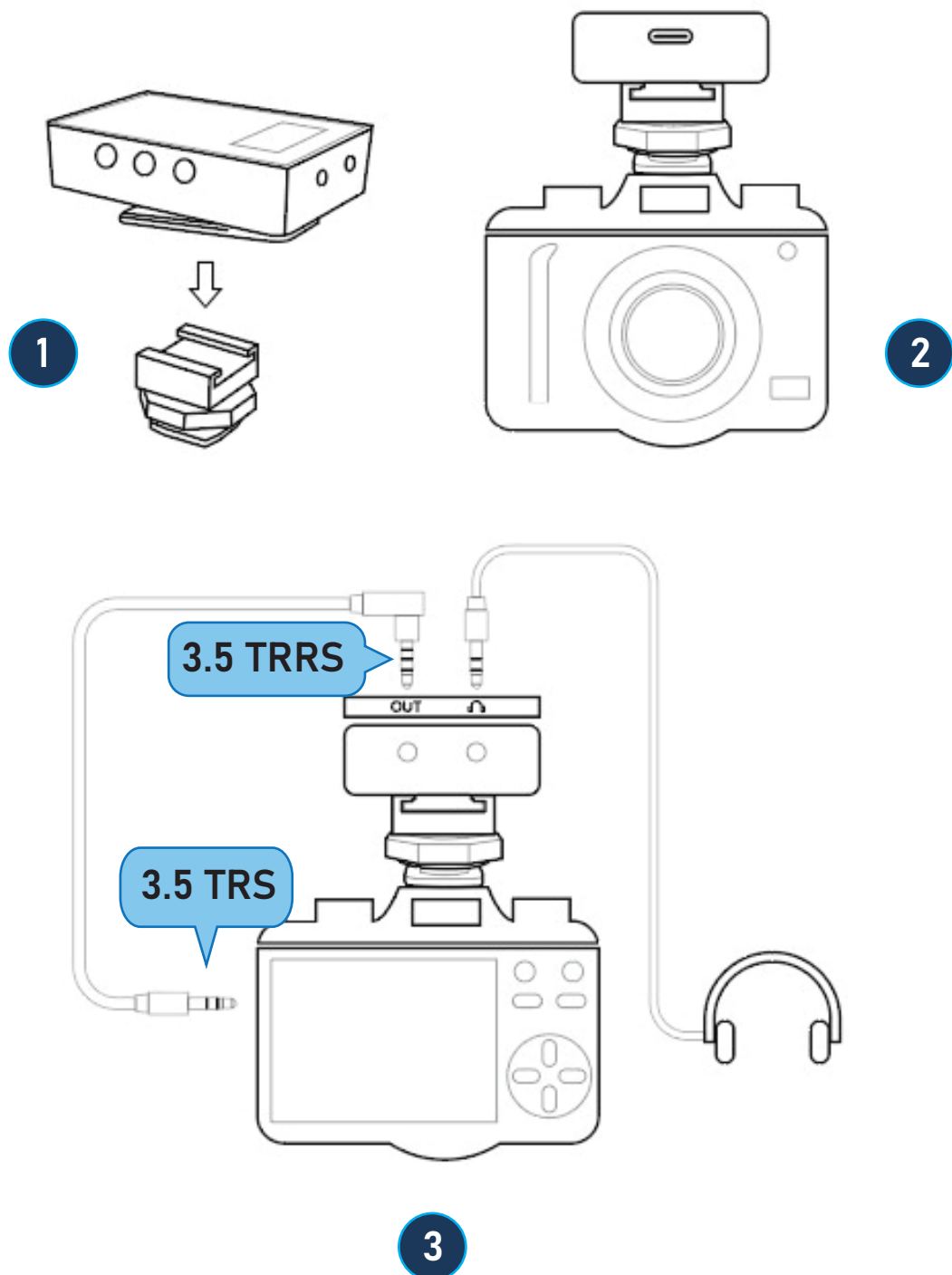

When using with a phone

When connecting the receiver to a cellphone, use either the provided 3.5 TRRS to 3.5 TRRS or 3.5 TRRS to USB Type-C depending on your device.

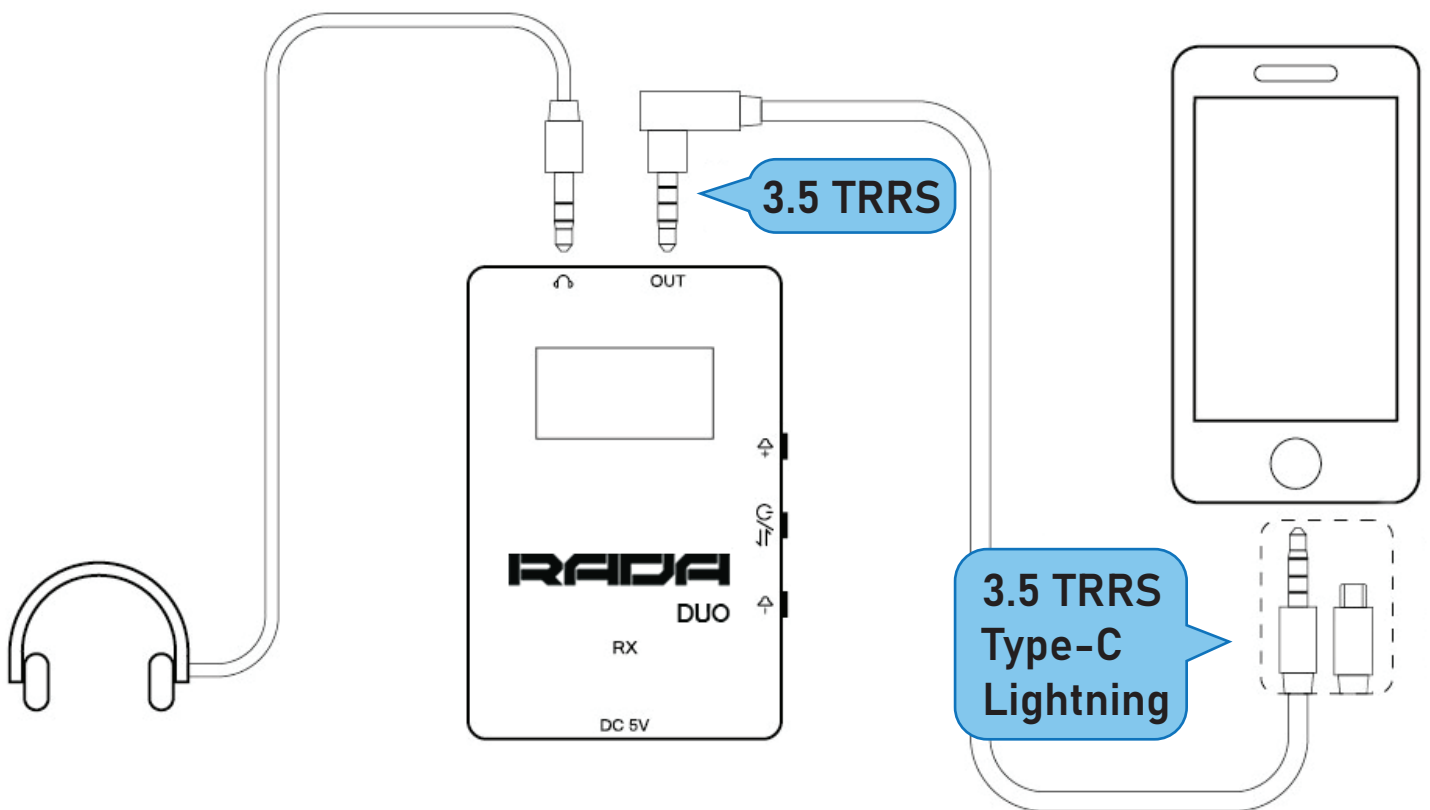

When using with a computer

When connecting the receiver to a computer or other devices, use either the provided 3.5 TRRS to USB Type-C or USB Type-C to USB A adapter.

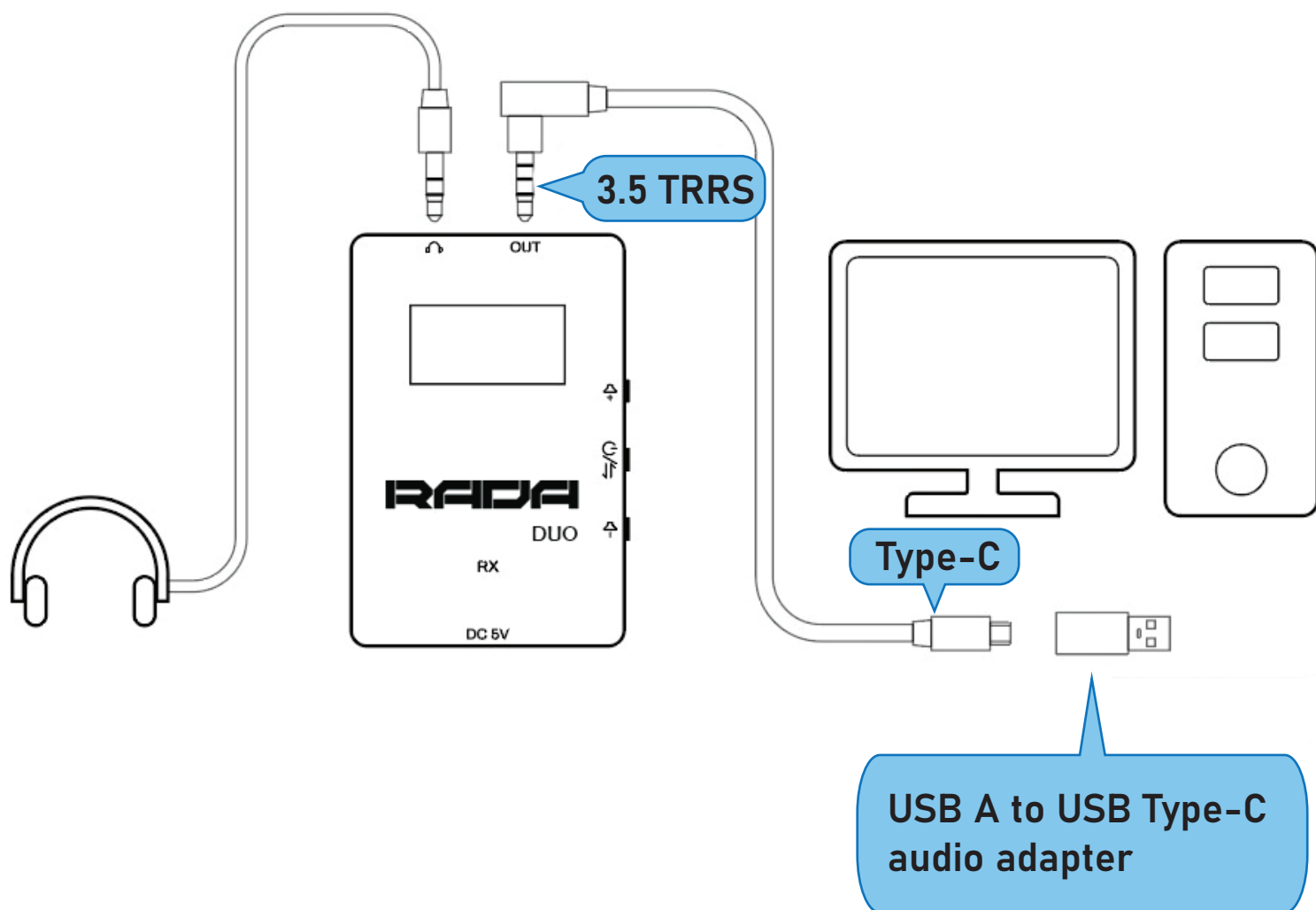

Configuring the devices

For the transmitter – press power button for 2 seconds to turn on or turn off the device. When powered on, press power button to cycle through options for setting up channels, volume, or LCF. Adjust these settings using “+” or “-” buttons. Settings are automatically saved after 2 seconds. You can also save manually by pressing the power button.

For the receiver – increase the volume by pressing “+” button and decrease by pressing “-”.

Devices are shipped already paired. In case you need to pair the devices again or fix channel misalignment, follow this procedure :

1. Power on the devices
2. On the receiver, press power button 3 times to enter pairing (coding) mode
3. On the transmitters, press “+” button three times to do the same

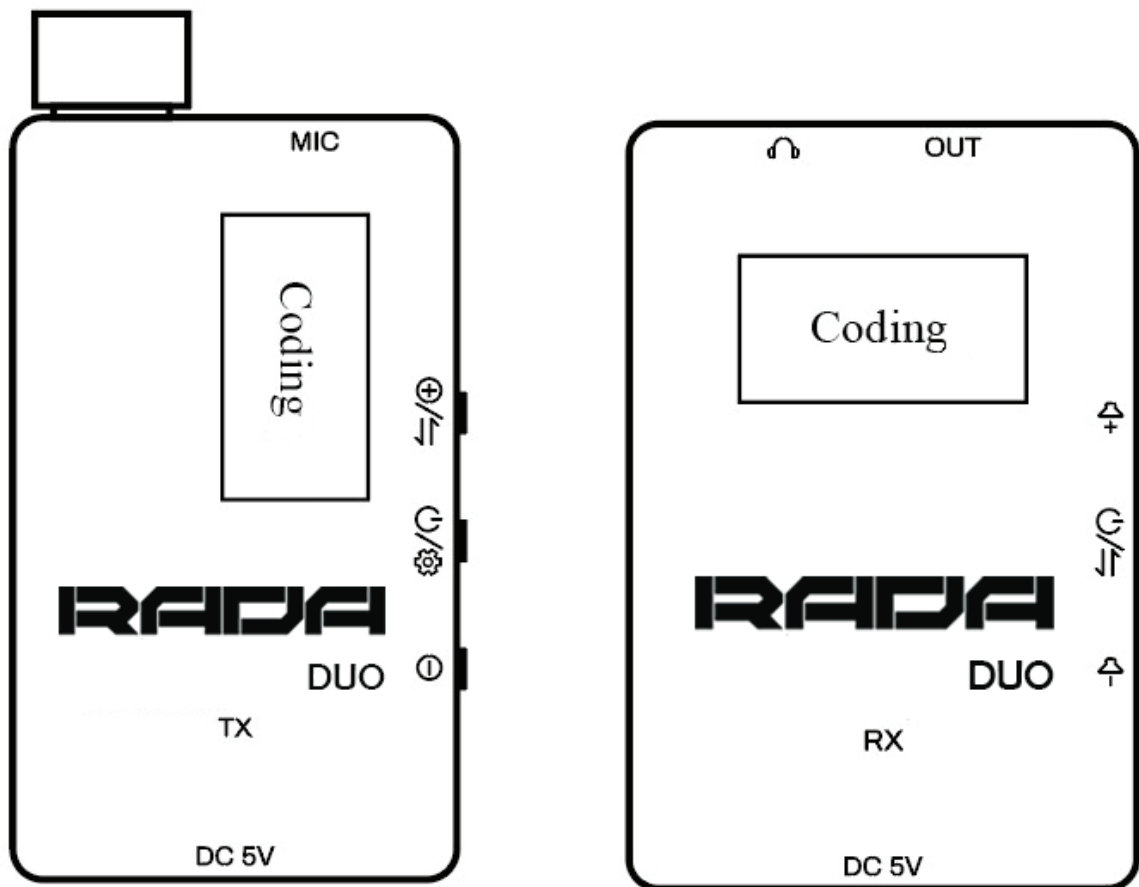

Troubleshooting

1. Objects and walls can block the devices and reduce effective range. In crowded environments particularly, human bodies attenuate radio waves, and thus it is important to keep the devices free from obstruction. If you are getting interference or low signal, try clearing the obstacles
2. When using outdoors or speaking directly into the microphone, it is recommended to use the windshield to prevent distortion and wind background noise
3. If you are experiencing audio issues, check that the cables are properly connected
4. If you are not getting audio, make sure that the devices are properly paired (coded). Follow the pairing guide above if needed
5. It is possible to mute the devices. If you are not getting audio, please check the volume level on the devices
6. Try switching to a different channel if you are still experiencing interference
7. If your problem is not resolved by any of the above suggestions, please contact a-dena.com for further technical support

